

FREUDENBERG-NOK
TECNOLOGIA EM VEDAÇÃO

CATÁLOGO DE JUNTAS

LINHA PESADA

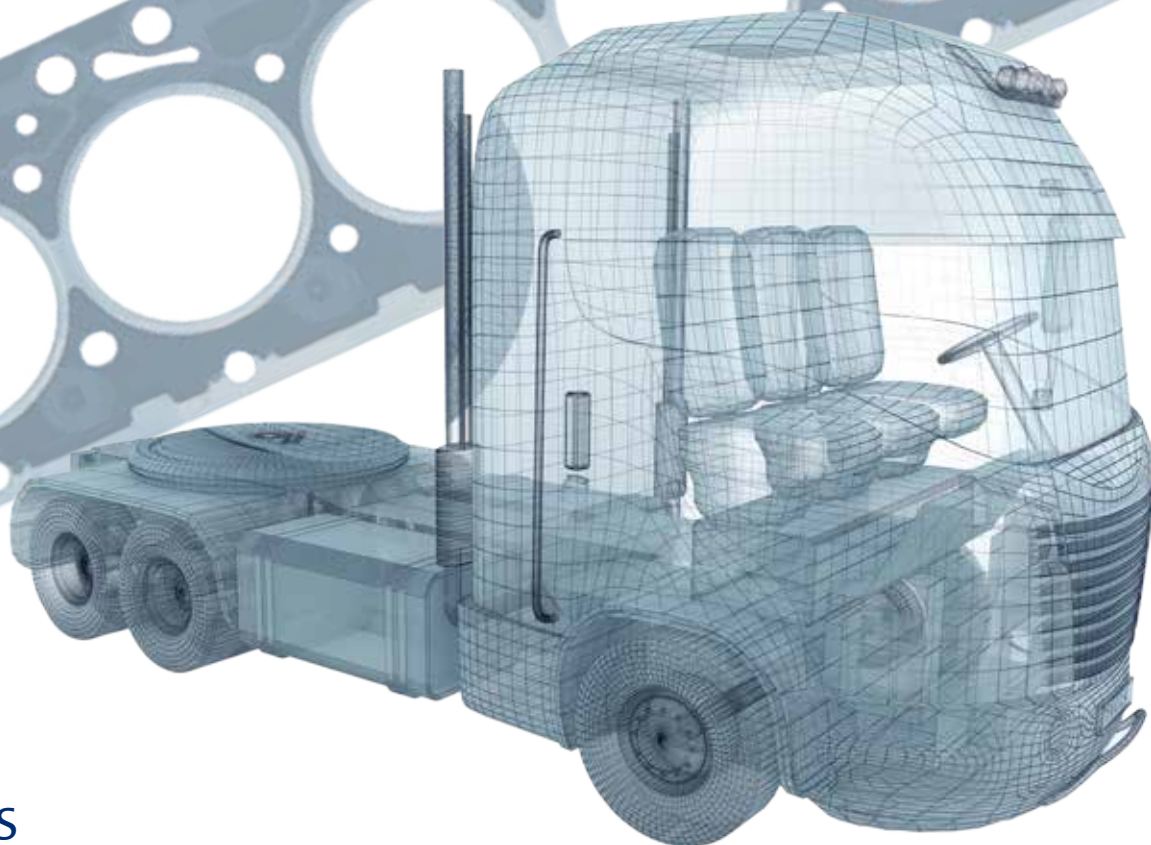

JUNTAS
GASKETS
EMPAQUETADURA



www.corteco.com.br

Seja original, seja Freudenberg-NOK



Divisão de Reposição

Sobre a Freudenberg-NOK

A Freudenberg-NOK é uma joint venture formada pela união da alemã Freudenberg com a japonesa NOK. A companhia atua nos mais diversos segmentos, como o automotivo, industrial e reposição. Especializada no desenvolvimento e produção de retentores, o-rings, vedações hidráulicas e pneumáticas, a Freudenberg-NOK integra a Unidade de Negócios de Tecnologia em Controle de Vibração e Vedação. Presente no Brasil desde 1973, a Freudenberg-NOK possui unidade fabril em Diadema (SP), onde emprega cerca de 500 pessoas. Além de atender a todas as montadoras e principais indústrias do país, exporta para a América Latina, Estados Unidos e Europa.

Sobre o Grupo Freudenberg

A Freudenberg é um grupo de tecnologia global que fortalece seus clientes e a sociedade de forma duradoura por meio de inovações orientadas para o futuro. Em conjunto com seus parceiros, clientes e o universo da ciência, o Grupo Freudenberg desenvolve tecnologias de ponta e produtos, excelentes soluções e serviços para mais de 30 segmentos do mercado e para milhares de aplicações: vedações, componentes para controle de vibração, não tecidos, filtros, especialidades químicas, produtos médicos e mecâtrônicos, serviços de TI e os mais modernos produtos de limpeza. Poder de inovação, intensa orientação ao cliente, diversidade e espírito de equipe são a base do nosso Grupo. Comprometimento com a excelência, confiabilidade e ação proativa e responsável fazem parte dos valores básicos da empresa, vivenciados por mais de 165 anos. Em 2014, o Grupo Freudenberg empregou mais de 40 mil pessoas em cerca de 60 países do mundo e gerou vendas de mais de 7 bilhões de Euros (incluindo joint ventures de consolidação proporcional de 50:50). Para obter mais informações, acesse www.freudenberg.com.br



Família de Produtos



Retentores



Kit de Roda com Rolamento

Linha Leve e Utilitário



- Composição:
- Retentores
 - Rolamento
 - Cupilha
 - Porca
 - Lubrificante



Kit de Direção Hidráulica

Linha Leve, Utilitário, Pesado e Ônibus



- Composição:
- Retentores
 - Juntas
 - Anéis de teflon
 - Anéis de nylon
 - Anéis em elastômero
 - Abraçadeiras
 - Travas
 - Tampões



Kit de Transmissão Automática

Linha Leve e Utilitário



- Composição:
- Retentores
 - Juntas
 - Arroelas de apoio
 - Abraçadeiras
 - O´rings
 - Anéis trava
 - Anéis vedação



Coxins Hidráulicos e Convencionais

Linha Leve e Utilitário



- Composição:
- Coxins de motor
 - Câmbio
 - Barra tensoras e bucha de bandeja



ÍNDICE POR MOTOR

CUMMINS	9
- AVULSOS CUMMINS	23
FORD	27
MAXION / PERKINS	31
- AVULSOS MAXION / PERKINS	47
MERCEDES-BENZ	51
- AVULSOS MERCEDES-BENZ	75
MWM	85
- AVULSOS MWM	101
SCANIA	107
- AVULSOS SCANIA	117
VALTRA	121
VOLVO	129
- AVULSOS VOLVO	137

Obs: Nos itens avulsos, o código de compra de cada peça é o que acompanha a imagem. | O código CORTECO no menu, refere-se ao kit onde as peças são aplicadas. O código comercial dos itens avulsos não acompanha a descrição do material. Ex: a peça 82264ECO-SC, o código comercial da mesma é 82264ECO.

LEGENDA DE MATERIAIS

CÓD.	MATERIAL
A	GAXETA
AC	AÇO MACIÇO
AI	AÇO INOX
AL	ALUMÍNIO MACIÇO
AN	PAPELÃO HIDRAULICO
BI	BORRACHA INJETADA EM METAL
BO	BORRACHA
CA	COBRE / AN
CB	CORTIÇA EMBORRACHADA
CB LT	CB COM LIMITADOR DE TORQUE
CI	AÇO COBREADO
CL	CORTIÇA EMBORRACHADA COM LONA
CU	COBRE MACIÇO
CV	AÇO VINCADO

CÓD.	MATERIAL
FB	FIBRA
FF	FLANDRES / AN
GA	GUARNITAL AMARELO
GV	GUARNITAL VERDE
KB	KIT DE BORRACHA
ML	MULTILAYER
NT	NITRAPACK (AN)
OR	ORIGINAL
PP	PAPEL PRESSPHAN
SC	SOLID CORE
SI	SILICONE
TM	TERMO MULTILAYER
VI	VITON

ÍNDICE DETALHADO

AGRÍCOLA

MOTOR	APLICAÇÃO PRINCIPAL	ANO DE FABRICAÇÃO	CORTECO	PÁGINA
MAXION / PERKINS 1006 / 1006-6T	MF-630/640/650/660/680/5320 - ASPIRADO / TURBO		70205ECO	42 e 43
MAXION / PERKINS 6.354	TRATOR MF-296 / DODGE D700 / D750 / D900		70206ECO	38 e 39
PERKINS D4.236 / 4.248 - AGRÍCOLA	D4.236 / 4.248 - AGRÍCOLA MF		70306ECO	32 e 33
VALTRA 320 DS - 3 CILS	BF65 / BF75 / SERIE 100 (600L/700L) / BL77		73320ECO	122 e 123
VALTRA 420 DS - 4 CILS	BM85 / BM100 / BM110 / SERIE 100 (800L/900L) BL88		73420ECO	124 e 125
VALTRA 620 DS - 6 CILS	BM120 / BH140HI / BH160HI / BH180HI		73620ECO	126 e 127

FORD

MOTOR	APLICAÇÃO PRINCIPAL	ANO DE FABRICAÇÃO	CORTECO	PÁGINA
PERKINS 6357	F600	1973 a 1980	70906ECO	40 e 41
F6600	FORD F4000 - 4CILS	1987/...	61406ECO	28 e 29

FORD / VOLKSWAGEN

MOTOR	APLICAÇÃO PRINCIPAL	ANO DE FABRICAÇÃO	CORTECO	PÁGINA
PERKINS 4236 / EURO 0/I	CAMINHAO VW 6.90 / DODGE D-400 / FORD F-350	1984 a 1988	80185ECO	34 e 35
MWM D229/4 / EURO 0/I	FORD: F1000 (1981 ATÉ 1995) / F4000 (1981 ATÉ 1995) / VW: 6.90 (1982 ATÉ 1990) / 7.90 (1982 ATÉ 1994) / 7.110 (1987 ATÉ 1995)	1982 a 1994	71112ECO 71109ECO	86 e 87 99, 105
MWM 6.10/6 CILINDROS - X-10	FORD: F12000 / F14000 / VW: 14150 / 14200 / 15180 / 16210 / 17210 / 23210 / 23240		71105ECO	92, 102
MWM D229-6	F600 / F 1000 / F2000 / F11000	1980 a 1992	71106ECO	88 e 89
MWM - MOTOR TD229 - 6CIL	VALMET 138/148 / VW / FORD		71119ECO	90 e 91
CUMMINS 4B-3,9 L	FORD C 712 / C 814 / C 815 / F 250 / F 350 / F 1000 / F4000 VW 9.150 E DELIVERY	1992/2004	60440ECO 79954ECO 02138ECO	10 e 11 10 e 11 10 e 11
CUMMINS 6B/6BT - 5.9 L EURO III	FORD CARGO C1215 / C1217 / C1415 / C 1417 / C 1521 / C 1617 / C 1621 / C 1717 / C 1721 / F 12000 / F 14000 / F 16000 VW 13.170 / 17.210/13.170 / 17210	1995 A 2002	60460ECO 79952ECO 00876ECO	12 e 13 12 e 13 12 e 13
CUMMINS ISB-4 3.9 L EURO III	FORD/F 350 /F4000 G / CARGO 815-E / C 1317E / C1517 E / C1717 E VW 8.150 E DELIVERY / 9.150 E DELIVERY	2000 a 2012	60540ECO	14 e 15
CUMMINS ISB-6 5,9 L / P5	FORD CARGO 1722 E /2422 E / 2428 E / 2622 E / 2628 E VW 24-250 CNC 6X2	2009 a 2011	60560ECO	16 e 17
CUMMINS 6C/6CT- 8,3 L EURO II	FORD C1630 / C 1731 / C 2630 / C 2831 / C 4030 / C 4331 // C 5031 / VW 16300 /17300 /18310 / 23310 / 26300- 1993 > 2002 VW 23.220	2002 a 2006	60660ECO	18 e 19
CUMMINS ISC	CARGO / C 2932 / C 4532 / C 6332 / VW 19320 CLC TT / 31320 CNC 6X4	ATE 2012	60760ECO 93310ECO 93330ECO	20 e 21 20 e 21 20 e 21

GENERAL MOTORS

MOTOR	APLICAÇÃO PRINCIPAL	ANO DE FABRICAÇÃO	CORTECO	PÁGINA
PERKINS S4T	6000T / 6100 / 6150/ D-20 / D-40		70305ECO	36 e 37

MERCEDES-BENZ

MOTOR	APLICAÇÃO PRINCIPAL	ANO DE FABRICAÇÃO	CORTECO	PÁGINA
OM314	M.BENZ/L 608 D	1984 a 1988	48306ECO	52 e 53
OM364	M.BENZ/709	1989 a 1993	80364ECO	54 e 55
OM364A/LA /LA -P5	M.BENZ/710	2004 a 2008	21740ECO	54 e 55
OM352	M.BENZ/ 1113 / OF 1113 / 1313 /1513 / 2013	1974 /1988	48806ECO	56 e 57
OM352A	M.BENZ/L 1318	1984 a 1988	48906ECO	56 e 57
OM352A	M.BENZ/L 1318	1984 a 1988	33180ECO	56 e 57
OM366	M.BENZ/OF 1315	1988 a 1993	48606ECO	58 e 59
OM366A / LA	M.BENZ/OF 1318 / 1618 /1620	1988 a 2005	80270ECO	58 e 59
OM355/6	MBB - OM355 - 6 CILINDROS		48908ECO	62 e 63
OM355/5	MBB - OM355 - 5 CILINDROS		48909ECO	60 e 61
OM447LA	M.BENZ/LS 1935 / 1838 S	1998/...	80281ECO	64 e 65
OM449LA	M.BENZ/LS 1935 / 1838 S	1998/...	80282ECO	64 e 65
OM447LA/449	M.BENZ/LS 1935 / 1838 S	1998/...	80326ECO	64 e 65
OM457LA	M.BENZ/LS 1634 / 1938 S	2004 A 2007	80295ECO 67790ECO	66 e 67 66 e 67
OM457LA	AXOR 2544 S / AXOR 2540 S/O500 RS 1836 /O500 RSD/O 500 RSDD / O500 MA /O500 UA / O 500 MDA /O 500 UDA	2007/...	48404ECO	68 e 69
OM457LA	AXOR 2544 S / AXOR 2540 S/O500 RS 1836 /O500 RSD/O 500 RSDD / O500 MA /O500 UA / O 500 MDA /O 500 UDA	2007/...	48405ECO	68 e 69
OM 904 LA	M.BENZ/L 1318 / 915C	2005 a 2012	80904ECO 47904ECO 47905ECO	70 e 71 70 e 71 70 e 71
OM924LA	M. BENZ /ATEGO 1719 / ACCELO 1016	2012/...	48770ECO 47924ECO	70 e 71 70 e 71
OM906LA	M. BENZ / ATEGO 2423 / 2425 / 2426	2005 a 2011	80906ECO 47906ECO 79906ECO	72 e 73 72 e 73 72 e 73
OM926LA	M. BENZ /O 500R- OF1724/ AXOR 1933 /2533	2003/...	48780ECO 47926ECO	72 e 73 72 e 73
OM611LA III	M. BENZ /313 CDI SPRINTER M / F	2007/2014	98950ECO	74
MWM INT. HS 2,5 L	M. BENZ / 310 D / 312 D / SPRINTER C / M / F 312 D SPRINTER M	1997/2001	80325ECO	44 e 45

SCANIA

MOTOR	APLICAÇÃO PRINCIPAL	ANO DE FABRICAÇÃO	CORTECO	PÁGINA
DN11 / DS11 / DSC-11	SCANIA - ÔNIBUS - K112/ L111 / L112/ S112/ K113/ L113/ S113/ BR115/ BR116/ SCANIA - CAMINHÕES - 112HW/ 113T/ 113R	1989/2000	80112ECO	114, 115 e 116
Scania DSC124 - 360	SCANIA - 114 P/R/T		59501ECO	112 e 113
DSC124 - 400 EV / 420 ELETRÔNICO	SCANIA - P340 / 380 / SCANIA - R380	2002/...	59505ECO	112 e 113
Scania DSC124 - SÉRIE 5	SCANIA - P230 / P250 / P270 / P310		59509ECO	113 e 115
DC11 /360	SCANIA - 114 P/R/T	1992/1998	80901ECO	110 e 111
DSC 12 / 380 / 400 / 420	SCANIA - P340 / 380 SCANIA - R380	2001/2006	80903ECO	110 e 111
LK MOD. V8	SCANIA - R/T 140 LK / LKS / LKT / 140 / 141R / T142 HW EW 410 / T143 / R143 H 2505	1978/1991	59806ECO	108 e 109

VOLKSWAGEN

MOTOR	APLICAÇÃO PRINCIPAL	ANO DE FABRICAÇÃO	CORTECO	PÁGINA
MWM 4.10 TCA / EURO III	VOLKSWAGEN - 7.100 / 8.120 / 8.140 / 8150	1994 a 2004	71104ECO 71111ECO	92 e 93 99
MWM 6.10 TCA / EURO III	VOLKSWAGEN - 13.180 / 13.180 CNM	2000 a 2012	71103ECO	94 e 95

VOLKSWAGEN / AGRALE / GENERAL MOTORS

MOTOR	APLICAÇÃO PRINCIPAL	ANO DE FABRICAÇÃO	CORTECO	PÁGINA
MWM SPRINT 4.07 4 CILINDROS -	VOLARE / TROLLER / AGRALLE 600 / S10 / BLAZER	2004 a 2012	71004ECO	98

VOLKSWAGEN / AGRALE / VOLVO

MOTOR	APLICAÇÃO PRINCIPAL	ANO DE FABRICAÇÃO	CORTECO	PÁGINA
MWM 412 ACTEON - X12 - 4CILS	AGRALE 8500E / 9200E / VOLVO VM210 / VW CAMINHOES 13.180E / 15.180E / 8150EOD / 9150EOD		71412ECO	96 e 97
MWM 412 / 612ACTEON - X12 - 4 / 6 CILS	AGRALE 8500E/9200E / VOLVO VM210 / VW CAMINHOES 13.180E / 15.180E / 8150EOD / 9150EOD		71413ECO	96 e 97

VOLVO

MOTOR	APLICAÇÃO PRINCIPAL	ANO DE FABRICAÇÃO	CORTECO	PÁGINA
MWM ACTEON 6.12 TCE 7,2 L / (X12-2V) EURO III	VOLVO / VM 260 6X2R	2009 a 2011	13860ECO	96 e 97
NL10 / TD102F / TD 102 FS	VOLVO - NL10 340 4X2	1989 a 1999	80320ECO	130 e 131
NL10 EDC (137mm)	VOLVO - NL10 340 4X2	1989 a 1999	17060ECO	130 e 131
NL12 / TD122 F / TD 122 FS / (147mm)	VOLVO - NL12 360 4X2T EDC	1989 a 1999	80322ECO	132 e 133
NL12 EDC / (147mm)	VOLVO - NL12 360 4X2T EDC	1989 a 1999	80321ECO	132 e 133
FH12 - D12C - 380	VOLVO/FH12 380 4X2T	2004 a 2008	49012ECO	134 e 135

FREUDENBERG-NOK

TECNOLOGIA EM VEDAÇÃO



A Freudenberg - Corteco disponibiliza para o mercado de reposição a linha completa de **KITS DE REPARO DE CÂMBIOS, EIXOS E TRANSMISSÃO AUTOMÁTICA** (linha leve). São componentes originais desenvolvidos em conformidade com as rigorosas exigências internacionais de qualidade das montadoras e das normas ambientais.

www.corteco.com



Divisão de Reposição

Seja original, seja Freudenberg-NOK

KITS DE JUNTAS

CUMMINS

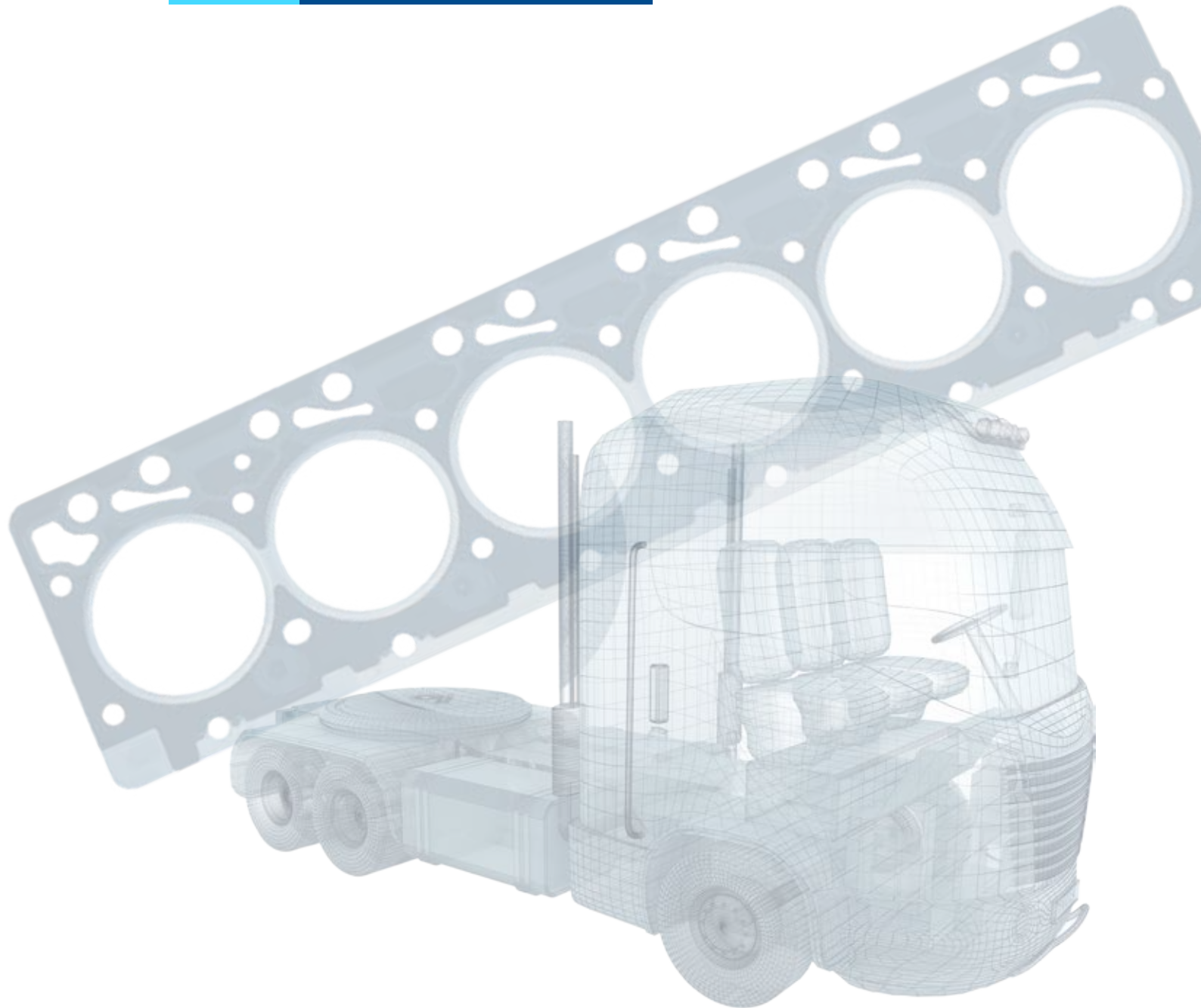

**CUMMINS
4B/BTA - 3.9L**

**Componentes
do Jogo**

11445-SC	1	1
11447-AN	1	1
11448-FL	4	4
11449-AN	2	2
11451-AN	2	2
11452-SI	4	4
11453-BO	1	1
11855-BO	1	1
11857-BO	1	1
11858-SI	4	4
11859-BO	1	1
11860-BO	1	1
11861-BO	1	1
11862-BO	1	1
11863-BO	6	6
11454-FB	8	8
11864-BO	1	1
11455-AI	1	1
11457-AI	1	1
11459-SC	1	1
11460-SC	1	1
11462-AN	1	1
11463-AN	1	1
11464-AN	1	1
11467-AN	1	1
11470-CB	1	1
11472-AN	1	1
11473-AN	1	1
11474-SC	1	1
11475-AN	1	1
11476-AN	1	1
11477-AI	1	1
11481-SC	1	1
11489-CU	4	4
11867-EP	6	6
11494-AN	1	1
11873-VI	1	1
11875-VI	1	1
11878-BO	1	1
11503-SC	1	1
11882-PE	4	4
7647T	1	1
9117V	8	8
7648T	1	1
11923-AC	2	2
11770-AL	4	4
11766-CU	1	2
11767-CU	2	4
11773-CU	6	6

Quantidades

N° CORTECO **DESCRIÇÃO DO JOGO**

79954ECO	RETIFICA VÁLVULAS CUMMINS 4B 4 CILINDROS C/RETENTOR
02138ECO	RETIFICA BLOCO CUMMINS 4B 4 CILINDROS C/RETENTOR
60440ECO	JOGO DE JUNTAS COMPLETO CUMMINS 4B 4 CILINDROS C/RETENTORES

BOMBA DE ÓLEO



BOMBA HIDRÁULICA



**BORRIFADOR
SAÍDA PISTÃO**



VEDADOR



RETENTOR HASTE VÁLVULAS



RETENTOR DIANTEIRO



RETENTOR TRASEIRO



ARRUELA GEMEA INJETOR



ANEL O-RING



**VED.PRIS.DA
TPA DE VÁLVULA**



ARRUELA



ARRUELA



ARRUELA



ARRUELA CARTER



ARRUELA CARTER



**ANEL VEDADOR
INJETOR**



ANEL VEDADOR



ANEL VEDADOR



ANEL VEDADOR

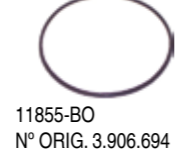

ANEL VEDADOR



ANEL VEDADOR



ANEL VEDADOR

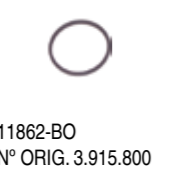

ANEL VEDADOR



ANEL VEDADOR



**ANEL VEDADOR
DA TAMPA TRASEIRA**



CABEÇOTE



TAMPA DE VÁLVULAS



**COLETOR ESCAPAMENTO
(MULTICAMADAS)**



TUBO DA ADMISSÃO



TAMPA DISTRIBUIÇÃO

11481-SC
N° ORIG. 3914385

CARTER

11447-AN
N° ORIG. 3938162



COLETOR ADMISSÃO

11449-AN
N° ORIG. 3938153



TAMPA LATERAL

11453-BO
N° ORIG. 3283767



JUNTA

11476-AN
N° ORIG. 3.938.157



**VED.PRIS.TPA DE
VÁLVULAS 4BT**



BOMBA INJETORA



VÁLVULA TERMOSTÁTICA



**CARCAÇA
ENGRENAGEM**

11462-AN
N° ORIG. 3938156



**VED.PRIS.TPA DE
VÁLVULAS 4BT**



BOMBA INJETORA



VÁLVULA TERMOSTÁTICA



TUBO DRENO ÓLEO



**REGULADOR
PINO CARÇAÇA**



**SAIDA CONEXÃO
DA TURBINA**



ANEL TURBINA



TAMPA RESFRIADOR

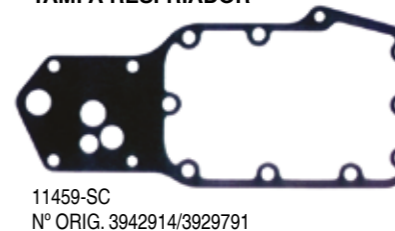

RESFRIADOR ÓLEO



BOMBA HIDRÁULICA



BASE DA TURBINA



PLACA TAMPA DA DISTRIB.



TAMPA PLATO



**CUMMINS
6B/BT - 5.9L**

**Componentes
do Jogo**

N° CORTECO

DESCRIÇÃO DO JOGO

79952ECO	RETIFICA VÁLVULAS CUMMINS SERIE B 6 CILINDROS C/RETENTOR
00876ECO	RETIFICA BLOCO CUMMINS 6B C/RETENTOR
60460ECO	JOGO DE JUNTAS COMPLETO CUMMINS 6B C/RETENTORES

BOMBA HIDRÁULICA COMPRESSOR TAMPA PLATO RETENTOR TRASEIRO

11475-AN N° ORIG. 3918340	11471-SC N° ORIG. 3008400	11503-SC N° ORIG. 3931348	7648T N° ORIG. 3909410

VEDADOR	BICO RESFRIADOR	VED.PRIS.DA TPA DE VÁLVULA	ARRUELA	ARRUELA	ARRUELA
11864-BO N° ORIG. 3.923.331	11883-PE N° ORIG. 3901020	11858-SI N° ORIG. 3.930.543	11923-AC	11770-AL	11454-FB N° ORIG. 3.928.759

RETENTOR HASTE VÁLVULAS	RETENTOR DIANTEIRO	PLACA TAMPA	BORRIFADOR SAÍDA PISTÃO
9117V N° ORIG. 3921640	7647T N° ORIG. 3904353	11470-CB N° ORIG. 3908096	11882-PE N° ORIG. 3930139

ARRUELA GEMEA INJETOR	ARRUELA CARTER	ARRUELA CARTER	ARRUELA VEDAÇÃO
11489-CU N° ORIG. 3903380	11766-CU N° ORIG. 3920773	11767-CU N° ORIG. 3902425	11773-CU N° ORIG. 3906659

ANEL VEDADOR	ANEL VEDADOR	ANEL VEDADOR	ANEL VEDADOR	ANEL TURBINA
11875-VI N° ORIG. 3.915.772	11855-BO N° ORIG. 3.906.694	11856-SI N° ORIG. 3.883.284	11857-BO N° ORIG. 3.936.876	11477-AI N° ORIG. 3.354.864

ANEL VEDADOR DA TAMPA TRASEIRA	ANEL VEDADOR	ANEL VEDADOR	ANEL VEDADOR	ANEL VEDADOR
11878-BO N° ORIG. 3912473	11860-BO	11859-BO N° ORIG. 3.906.697	11861-BO N° ORIG. 3.906.696	11862-BO N° ORIG. 3.915.800
			ANEL O-RING	
			11867-EP N° ORIG. 3910824	

CABEÇOTE

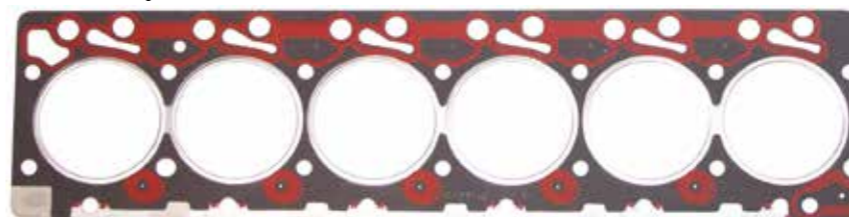

11446-SC
N° ORIG. 3.283.335



CARTER
11465-AN
N° ORIG. 3937072

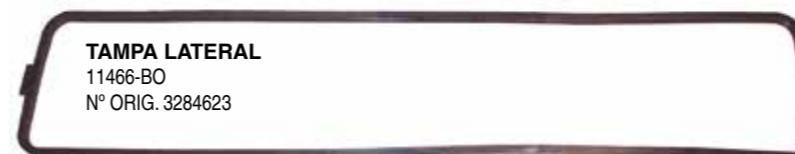

TAMPA LATERAL
11466-BO
N° ORIG. 3284623

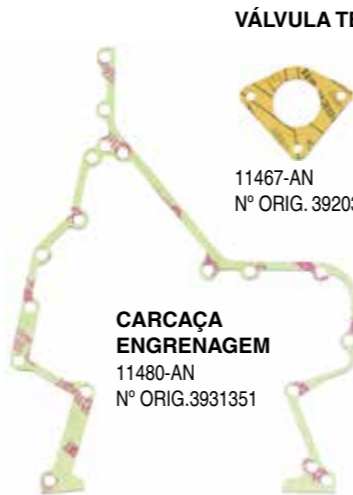

CARCAÇA ENGRENAGEM
11480-AN
N° ORIG. 3931351

BASE DA TURBINA



11457-AI
N° ORIG. 3901356

SAIDA CONEXÃO DA TURBINA



11455-AI
N° ORIG. 3912220

BOMBA INJETORA



11472-AN
N° ORIG. 3931607



11459-SC
N° ORIG. 3942914/3929791



RESFRIADOR ÓLEO

11460-SC
N° ORIG. 3929792



FILTRO ÓLEO

11461-SC
N° ORIG. 3942915



TAMPA DE VÁLVULA

11452-SI
N° ORIG. 3902666



TAMPA DISTRIBUIÇÃO

11481-SC
N° ORIG. 3914385

TUBO DO COLETOR ADMISSÃO



11451-AN
N° ORIG. 3931604

COLETOR ESCAPAMENTO (MULTICAMADAS)



11448-FL
N° ORIG. 3927154



TAMPA DISTRIBUIÇÃO

11018-SC
N° ORIG. 3918673

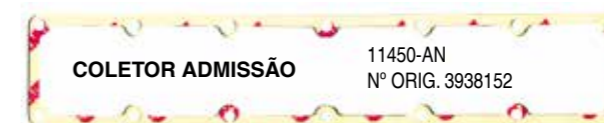

COLETOR ADMISSÃO
11450-AN
N° ORIG. 3938152



JUNTA

11474-SC
N° ORIG. 391349



ANEL VEDAÇÃO PINO AJUSTE

11873-VI
N° ORIG. 3913994

TUBO DRENO ÓLEO



11494-AN
N° ORIG. 3937706/3931350

JUNTA



11476-AN
N° ORIG. 391383

**CUMMINS
ISB4 (ELETRÔNICO)
INTERACT 3.9L**

N° CORTECO **DESCRIÇÃO DO JOGO**
60540ECO JOGO DE JUNTAS COMPLETOR CUMMINS ISB 4 CILINDROS C/ RETENOR

Componentes do Jogo

- 11415-AN
- 11416-BO
- 11417-BO
- 11418-BO
- 11421-TM
- 11423-BO
- 11424-SC
- 11425-AN
- 11426-AN
- 11456-AI
- 11458-BI
- 11457-AI
- 11781-ML
- 8427T
- 8428T
- 8429V
- 7648T
- 11877-PE
- 11880-PE
- 11882-PE
- KB-11941
- KB-11942
- 11765-AL
- 11774-AL
- 11773-CU
- 11503-SC

- Quantidades
- 1
 - 1
 - 1
 - 1
 - 4
 - 1
 - 1
 - 1
 - 1
 - 1
 - 1
 - 1
 - 1
 - 1
 - 1
 - 16
 - 1
 - 4
 - 4
 - 4
 - 1
 - 1
 - 2
 - 4
 - 4
 - 1

SUCÇÃO BOMBA DE ÓLEO



11425-AN
N° ORIG. 4898301

RETENOR HASTE VÁLVULAS



8429V
N° ORIG. 3955393

RETENOR DIANTEIRO



8427T
N° ORIG. 4890832

RETENOR TRASEIRO



7648T
N° ORIG. 3909410
LINHA VW - 01.07.2003 / 30.06.2006
LINHA FORD - 07.02.2005 / 28.10.2006

RETENOR TRASEIRO



8428T
N° ORIG. 4890833
LINHA VW - 07.2006 / ...
LINHA FORD - 11.2006 / ...

BORRIFADOR SAÍDA PISTÃO



11882-PE
N° ORIG. 3937214

BORRIFADOR SAÍDA PISTÃO



11877-PE
N° ORIG. 3930139

BORRIFADOR PISTÃO (TAMPÃO)



11880-PE
N° ORIG. 3901020

TAMPA PLATO



11503-SC
N° ORIG. 3931348

KB-11941

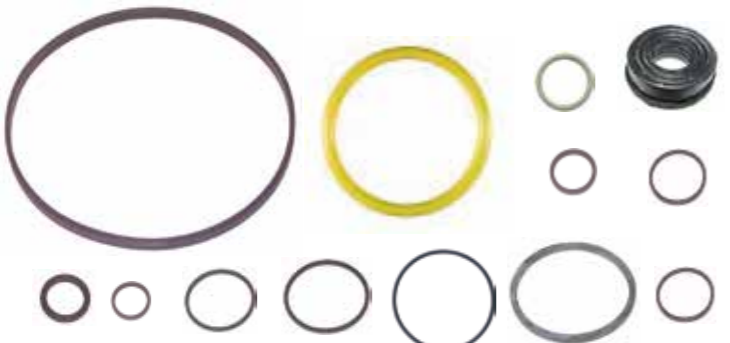

KB-11942



CABEÇOTE



11781-ML (1,25 mm)
N° ORIG. 2.830.706

COLETOR DE ESCAPAMENTO



11421-TM
N° ORIG. 3955339

ARRUELA VEDAÇÃO



11765-AL

ARRUELA VEDAÇÃO



11774-AL



TAMPA DE VÁLVULAS
11417-BO
N° ORIG. 4899228

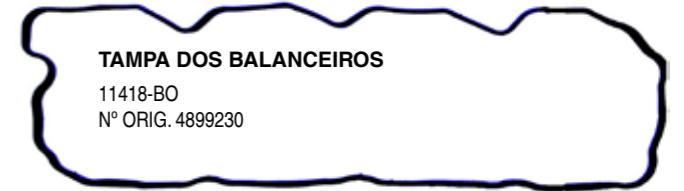

TAMPA DOS BALANCEIROS
11418-BO
N° ORIG. 4899230



CARTER
11416-BO
N° ORIG. 44939246



CARTER
11415-AN
N° ORIG. 3972701

SAIDA DA TURBINA



11456-AI
N° ORIG. 3932475

TAMPA RESFRIADOR



11458-BI
N° ORIG. 4895742

RESFRIADOR ÓLEO



11423-BO
N° ORIG. 4896409

MESA TURBINA



11457-AI
N° ORIG. 3901356

SAIDA DE ÓLEO DA TURBINA



11426-AN
N° ORIG. 4891288

BOMBA HIDRÁULICA



11424-SC
N° ORIG. 4896897

ARRUELA VEDAÇÃO



11773-CU
N° ORIG. 3906659

**CUMMINS
ISB6 (ELETRÔNICO)
INTERACT 5.9L**

N° CORTECO DESCRIÇÃO DO JOGO

60560ECO JOGO DE JUNTAS COMPLETO CUMMINS ISB 6 CILINDROS C/RETENTOR

**Componentes
do Jogo**

- 11419-AN
- 11420-BO
- 11422-BO
- 11021-BO
- 11421-TM
- 11423-BO
- 11424-SC
- 11425-AN
- 11426-AN
- 11456-AI
- 11457-AI
- 11458-BI
- 11782-ML
- 8427T
- 8428T
- 8429V
- 7648T
- 11877-PE
- 11880-PE
- 11882-PE
- 11765-AL
- 11774-AL
- 11773-CU
- KB-11943
- KB-11944
- 11503-SC

60560ECO

Quantidades

SUCÇÃO BOMBA DE ÓLEO	SAIDA DA TURBINA	MESA TURBINA	BOMBA HIDRÁULICA
 11425-AN N° ORIG. 4898301	 11456-AI N° ORIG. 3932475	 11457-AI N° ORIG. 3901356	 11424-SC N° ORIG. 4896897
ARRUELA VEDAÇÃO	ARRUELA VEDAÇÃO	ARRUELA VEDAÇÃO	TAMPA PLATO
 11773-CU N° ORIG. 3906659	 11765-AL	 11774-AL	 11503-SC N° ORIG. 3931348
SAIDA DE ÓLEO DA TURBINA	RETENTOR HASTE VÁLVULAS	RETENTOR DIANTEIRO	
 11426-AN N° ORIG. 4891288	 8429V N° ORIG. 3955393	 8427T N° ORIG. 4890832	

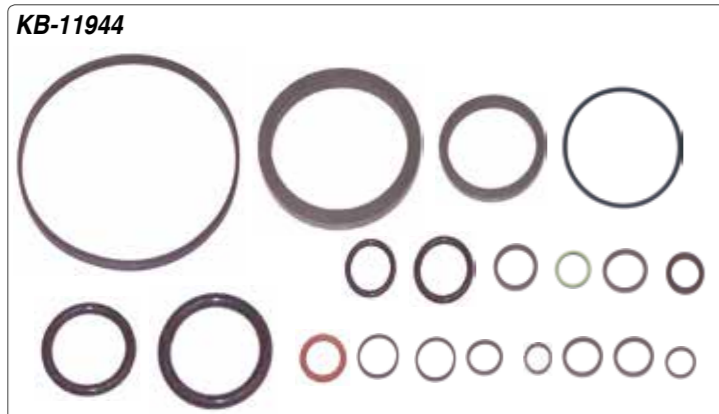
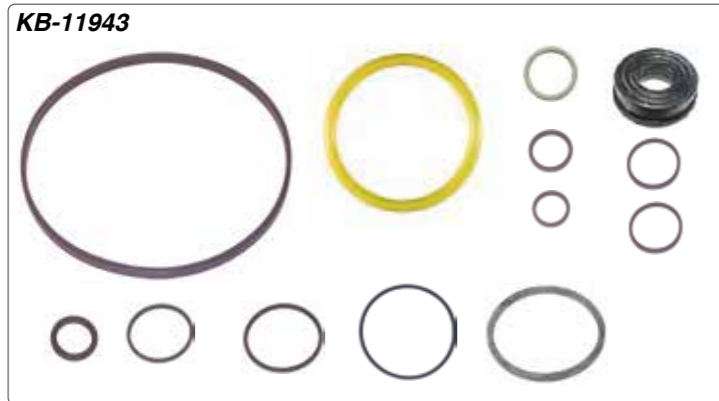

CABEÇOTE



11782-ML (1,25 mm)
N° ORIG. 2.830.704

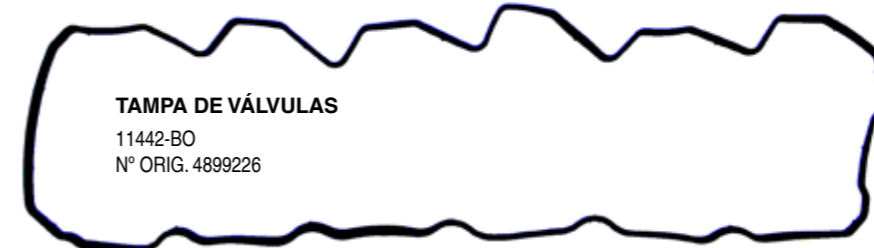

COLETOR DE ESCAPAMENTO



11421-TM
N° ORIG. 3955339

RESFRIADOR ÓLEO



11423-BO
N° ORIG. 4896409

TAMPA RESFRIADOR



11458-BI
N° ORIG. 4895742

BORRIFADOR SAÍDA PISTÃO



11882-PE
N° ORIG. 3937214

BORRIFADOR SAÍDA PISTÃO



11877-PE
N° ORIG. 3930139

BORRIFADOR PISTÃO (TAMPÃO)



11880-PE
N° ORIG. 3901020

**CUMMINS
6C - 8.3L**

N° CORTECO **DESCRIÇÃO DO JOGO**

60660ECO JOGO DE JUNTAS COMPLETO CUMMINS SERIE C - C/RETENORES

Componentes do Jogo

- 11468-AN 1
- 11469-AN 1
- 11475-AN 1
- 11478-AI 1
- 11479-AI 1
- 11482-SC 1
- 11483-AN 1
- 11484-FL 6
- 11485-AN 1
- 11486-AN 1
- 11487-AI 1
- 11488-SI 1
- 11865-BO 2
- 11866-BO 1
- 11867-EP 6
- 11868-BO 1
- 11869-BO 1
- 11870-EP 1
- 11489-CU 7
- 11490-AC 12
- 7751V 12
- 11871-BO 1
- 11491-AN 1
- 11492-AN 1
- 11493-AN 1
- 11494-AN 1
- 11872-SI 1
- 11873-VI 1
- 11874-VI 1
- 11875-VI 1
- 11876-VI 1
- 11877-PE 12
- 11878-BO 1
- 11879-BO 1
- 11496-AN 1
- 11497-SC 1
- 11498-SC 1
- 11499-SC 1
- 11500-SC 1
- 11501-SC 1
- 11502-SC 1
- 11503-SC 1
- 11504-AN 1
- 11884-PE 6
- 7649T 1
- 7648T 1
- 11760-CU 6
- 11762-CU 6
- 11766-CU 1
- 11767-CU 3
- 11768-CU 1
- 11773-CU 6
- 11925-SI 2
- 11881-PE 6

Quantidades

RETENTOR HASTE VÁLVULAS	RETENTOR DIANTEIRO	RETENTOR TRASEIRO	TRAVA DO PRISIONEIRO COLET. ESCAPAMENTO		
7751V N° ORIG. 3927642/3915707	7649T N° ORIG.3353977	7648T N° ORIG. 3909410	11490-AC N° ORIG. 3914708		
BOMBA HIDRÁULICA	BOMBA HIDRÁULICA	BICO RESFRIADOR PISTÃO	BICO RESFRIADOR PISTÃO	TUBO ÓLEO	
11475-AN N° ORIG. 3918340	11504-AN N° ORIG. 3916042	11877-PE N° ORIG.3928031	11881-PE N° ORIG.3928031	11497-SC N° ORIG. 3914302	
ARRUELA GEMEA INJETOR	ANEL VEDADOR BICO INJETOR	ARRUELA VEDAÇÃO	ARRUELA VEDAÇÃO	ARRUELA VEDAÇÃO	TAMPA PLATO
11489-CU N° ORIG.3903380	11773-CU N° ORIG. 3909886	11760-CU N° ORIG.3935171	11762-CU N° ORIG.3935172	11925-SI	11503-SC N° ORIG.3931348
ARRUELA CARTER	ARRUELA CARTER	ARRUELA VEDAÇÃO	ANEL VEDAÇÃO PINO AJUSTE	ANEL O'RING	ANEL VEDAÇÃO BOMBA COMBUSTÍVEL
11766-CU N° ORIG.3920773	11767-CU N° ORIG. 3902425	11768-CU	11873-VI N° ORIG. 3913994	11867-EP N° ORIG. 3910824	11876-VI N° ORIG.3916284
ANEL O'RING FILTRO ÓLEO	ANEL VEDAÇÃO	ANEL VEDADOR	VEDADOR RETANGULAR TAMPA ENCHIMENTO ÓLEO	ANEL O'RING	
11865-BO N° ORIG. 145530	11875-VI N° ORIG. 3915772	11879-BO N° ORIG. 3935032	11866-BO N° ORIG.3902466	11870-EP N° ORIG.3909397	
ANEL VEDADOR TAMPA TRASEIRA		ANEL VEDADOR FILTRO	ANEL VEDAÇÃO	ANEL VEDAÇÃO BOMBA D'ÁGUA	ANEL O'RING
11878-BO N° ORIG.3912473		11869-BO N° ORIG. 3906695	11874-VI N° ORIG.3914095	11872-SI N° ORIG. 3902089	11686-BO N° ORIG. 3903546

CABEÇOTE



11482-SC
N° ORIG. 3967011

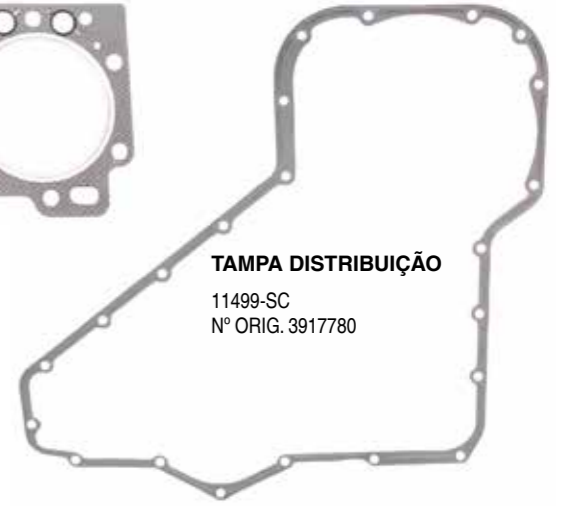

TAMPA DISTRIBUIÇÃO

11499-SC
N° ORIG. 3917780



CARTER

11483-AN
N° ORIG. 3938160

VED.DO PORTA INJETOR



11884-PE
N° ORIG.3909886



COLETOR ADMISSÃO

11485-AN
N° ORIG. 3414311



TAMPA COLETOR ADMISSÃO

11486-AN
N° ORIG.3921440



CARCAÇA DA ENGRENAGEM

11502-SC
N° ORIG.3929253



TAMPA TRASEIRA

11496-AN
N° ORIG.3914301

TAMPA DE VÁLVULAS



11488-SI
N° ORIG.3905449

CARCACA TERMOSTATO



11491-AN
N° ORIG.3914310



TAMPA RESFRIADOR (MAQ. AGRICOLA)

11498-SC
N° ORIG.3914308



RESFRIADOR ÓLEO (VEICULAR)

11500-SC
N° ORIG.3918174



FILTRO ÓLEO (VEICULAR)

11501-SC
N° ORIG.3929011



TUBO DA ADMISSÃO

11468-AN
N° ORIG. 3354398



BOCAL NIVEL ÓLEO

11469-AN
N° ORIG.3.354.389



VEDAÇÃO TAMPA INSPEÇÃO DISTRIBUIÇÃO

11871-BO
N° ORIG 3.903.475



TUBO DRENO ÓLEO

11494-AN
N° ORIG. 3937706



SAÍDA TUBO COMPRESSOR

100 mm



TURBO ALIMENTADOR

11487-AI
N° ORIG. 3911941



COLETOR DO ESCAPAMENTO (MULTICAMADAS)

11484-FL
N° ORIG.3.932.063



SAÍDA TUBO COMPRESSOR

82 mm

11478-AI
N° ORIG.3.352.494



CONEXÃO ENTRADA DE AR

11492-AN
N° ORIG. 3917892



CONEXAO AR

11493-AN
N° ORIG.3918779

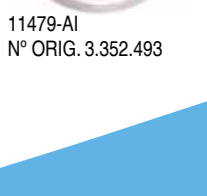

CONEXAO AR

11479-AI
N° ORIG. 3.352.493

**CUMMINS
ISC 6 CILS
ELETRÔNICO**

**Componentes
do Jogo**

11427-TM	6	6
11428-AN	1	1
11429-BO	1	1
11430-BO	1	1
11431-AN	1	1
11432-BI	1	1
11433-ML	1	1
11444-SC	1	1
11313-AI	1	1
11457-AI	1	1
11469-AN	1	1
11470-CB	1	1
11478-AI	1	1
11479-AI	1	1
11483-AN	1	1
11491-AN	1	1
11493-AN	1	1
11494-AN	1	1
8432V	24	24
11496-AN	1	1
11497-SC	1	1
11500-SC	1	1
11501-SC	1	1
11877-PE	6	6
7649T	1	1
11505-SC	1	1
11506-AN	1	1
11507-AN	1	1
7648T	1	1
11495-AN	1	1
11763-AL	5	5
11774-AL	25	13 38
11766-CU	1	1
11772-CU	6	6
KB-11945	1	1
KB-11946	1	1

N° CORTECO	DESCRIÇÃO DO JOGO
93310ECO	RETIFICA VÁLVULAS CUMMINS ISC ELETRONICO- C/RETENTOR VW / FORD
93330ECO	RETIFICA BLOCO CUMMINS ISC ELETRONICO- C/RETENTOR VW / FORD
60760ECO	JOGO DE JUNTAS COMPLETO CUMMINS ISC ELETRONICO- C/RETENTOR VW / FORD

RETENTOR HASTE VÁLVULAS	RETENTOR DIANTEIRO	RETENTOR TRASEIRO	TUBO CONEXÃO
8432V N° ORIG. 3943888	7649T N° ORIG.3353977	7648T N° ORIG. 3909410	11431-AN N° ORIG. 3945603
BOMBA HIDRÁULICA	BOMBA DE COMBUSTIVEL	CONEXAO DO TUBO AQUECEDOR	CARCACA TERMOSTATO
11432-BI N° ORIG. 3940245	11433-ML N° ORIG. 4902952	11428-AN N° ORIG. 3967891	11491-AN N° ORIG.3914310
TUBO DE ÓLEO	BICO RESFRIADOR PISTÃO	TAMPA TRASEIRA	FLANGE DO FILTRO ÓLEO
11497-SC N° ORIG. 3914302	11877-PE N° ORIG.3928031	11496-AN N° ORIG.3914301	11495-AN
RESFRIADOR ÓLEO (VEICULAR)	FILTRO ÓLEO (VEICULAR)		
11500-SC N° ORIG.3918174	11501-SC N° ORIG.3929011		

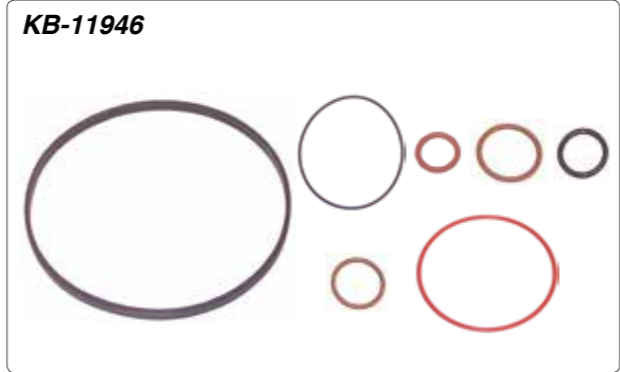

CABEÇOTE

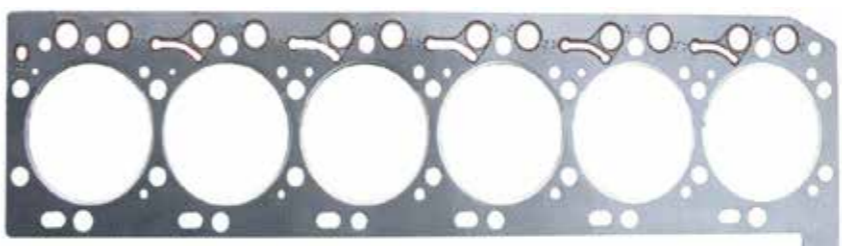

11505-SC
N° ORIG. 3.967.059
4.937.728

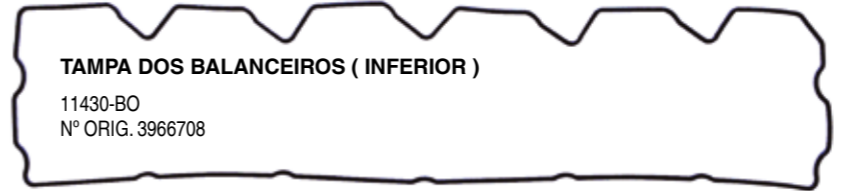

11507-AN
N° ORIG. 3992090



11469-AN



11313-AI



11457-AI
N° ORIG. 3901356



11478-AI
N° ORIG.3.352.494

ARRUELA VEDAÇÃO



11763-AL

ARRUELA VEDAÇÃO



11774-AL

COLETOR ESCAPAMENTO



11427-TM
N° ORIG.3937479



CONEXÃO DE AR



11493-AN
N° ORIG. 3918779

ARRUELA VEDAÇÃO



11766-CU
N° ORIG.3920773

ARRUELA VEDAÇÃO



11772-CU
N° ORIG. 3906659

TUBO DRENO ÓLEO



11494-AN
N° ORIG. 3937706/3931350

CARCAÇA DA TAMPA



11470-CB
N° ORIG.3.908.096

SAÍDA TUBO COMPRESSOR



11479-AI
N° ORIG. 3.352.493

ITENS AVULSOS

CUMMINS

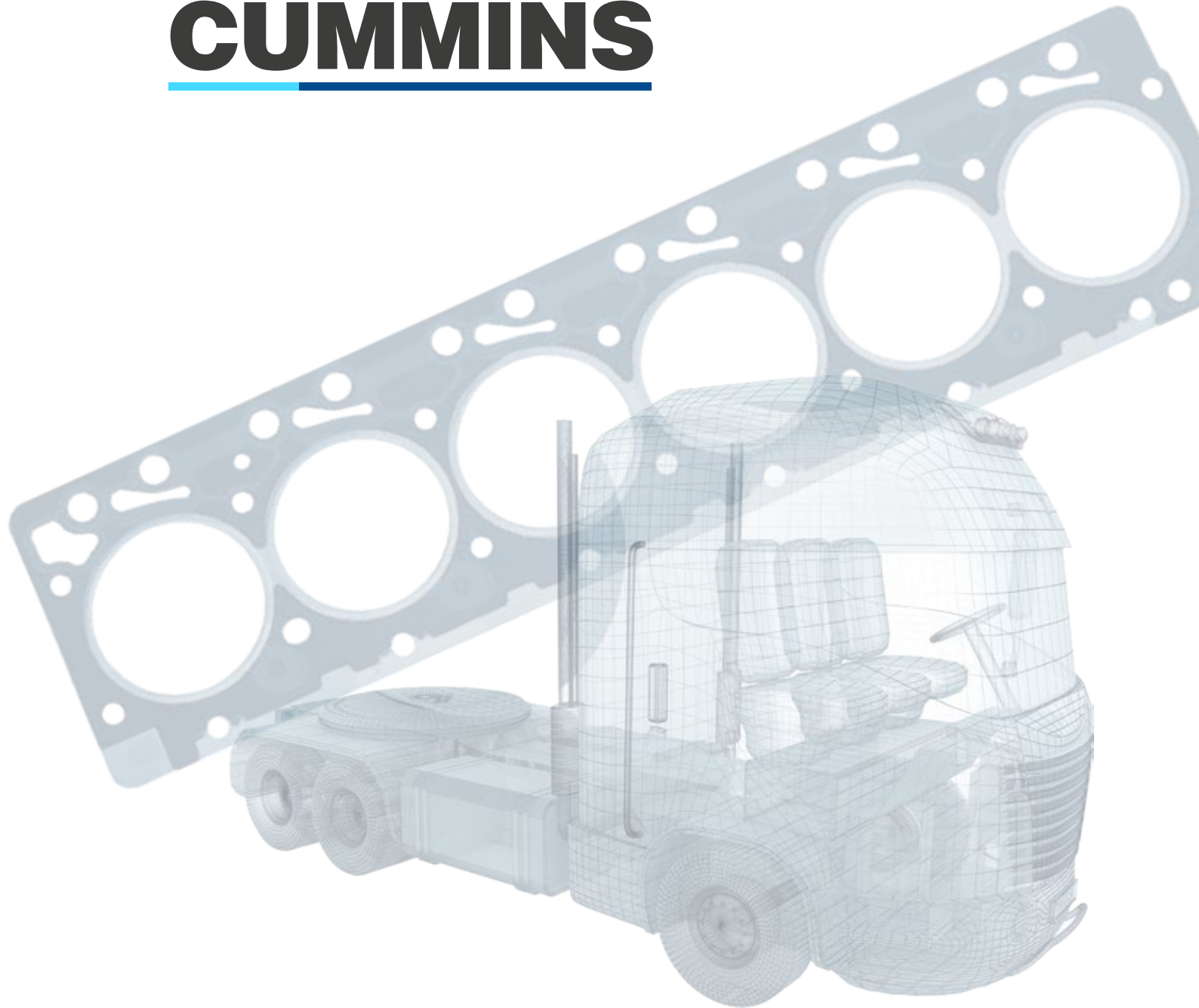

**CUMMINS
AVULSOS**

N° CORTECO 60440ECO, 79954ECO e 02138ECO
APLICAÇÃO CUMMINS 4B 4 CILINDROS

CABEÇOTE

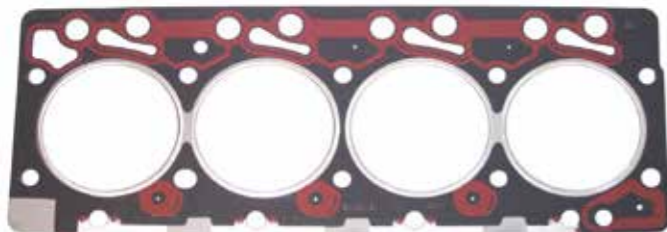

82284ECO-SC
N° ORIG.3.283.569

TAMPA DE VÁLVULAS



90040ECO-SI
N° ORIG.3902666



CARTER
96028ECO-AN
N° ORIG. 3938162

N° CORTECO 60460ECO, 79952ECO e 00876ECO
APLICAÇÃO CUMMINS SERIE 6B

CABEÇOTE

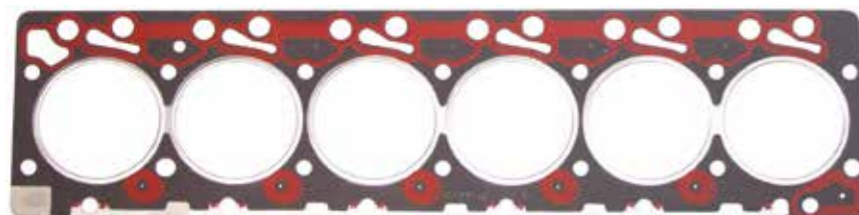

82285ECO-SC
N° ORIG.3.283.335

TAMPA DE VÁLVULA



90040ECO-SI
N° ORIG.3902666



CARTER
96027ECO-AN
N° ORIG. 3937072

N° CORTECO 60540ECO
APLICAÇÃO CUMMINS ISB 4 CILINDROS

CABEÇOTE



82352ECO-ML (1,25 mm)
N° ORIG.2.830.706



CARTER
60117ECO-AN
N° ORIG. 3972701



TAMPA DE VÁLVULAS
75642ECO-BO
N° ORIG. 4899228



CARTER
60116ECO-BO
N° ORIG. 44939246

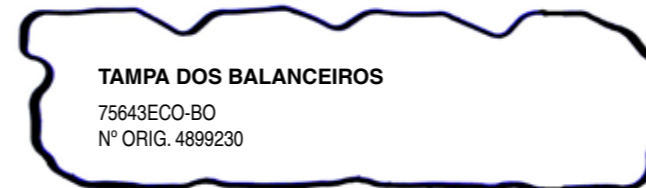

TAMPA DOS BALANCEIROS
75643ECO-BO
N° ORIG. 4899230

N° CORTECO 60660ECO
APLICAÇÃO CUMMINS SERIE C

CABEÇOTE



82283ECO-SC
N° ORIG. 3967011

TAMPA DE VÁLVULAS



75058ECO-SI
N° ORIG.3905449



CARTER
96029ECO-AN
N° ORIG. 3938160

N° CORTECO

93310ECO, 93330ECO e 60760ECO

APLICAÇÃO

CUMMINS ISC ELETRONICO - VW / FORD

CABEÇOTE

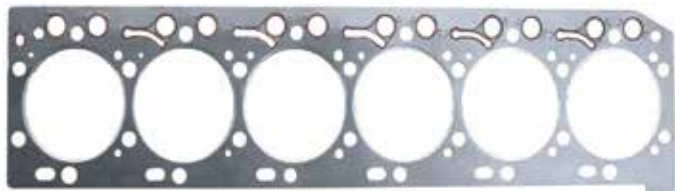

93180ECO-SC
N° ORIG. 3.967.059
4.937.728



CARTER
96029ECO-AN
N° ORIG. 3938160

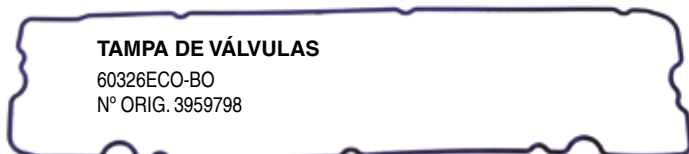

TAMPA DE VÁLVULAS
60326ECO-BO
N° ORIG. 3959798



TAMPA DOS BALANCEIROS (INFERIOR)
60327ECO-BO
N° ORIG. 3966708

N° CORTECO

60560ECO

APLICAÇÃO

CUMMINS ISB 6 CILINDROS

CABEÇOTE



82354ECO-ML (1,25 mm)
N° ORIG.2.830.704

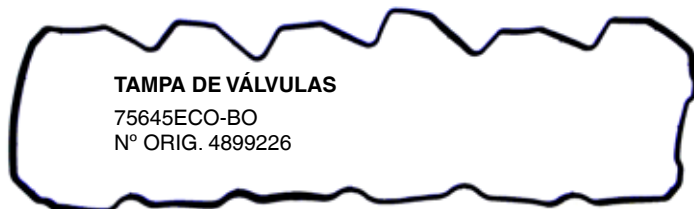

TAMPA DE VÁLVULAS
75645ECO-BO
N° ORIG. 4899226



CARTER
75647ECO-BO
N° ORIG. 3934344

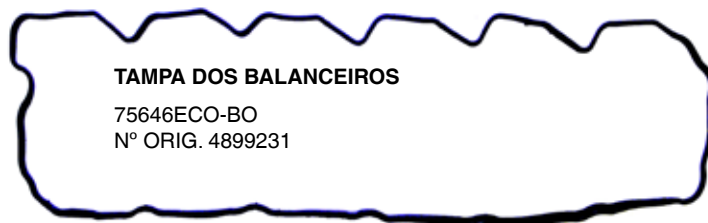

TAMPA DOS BALANCEIROS
75646ECO-BO
N° ORIG. 4899231

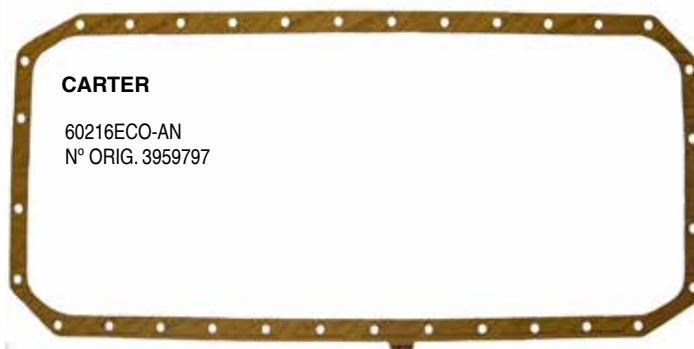

CARTER
60216ECO-AN
N° ORIG. 3959797

KITS DE JUNTAS
FORD

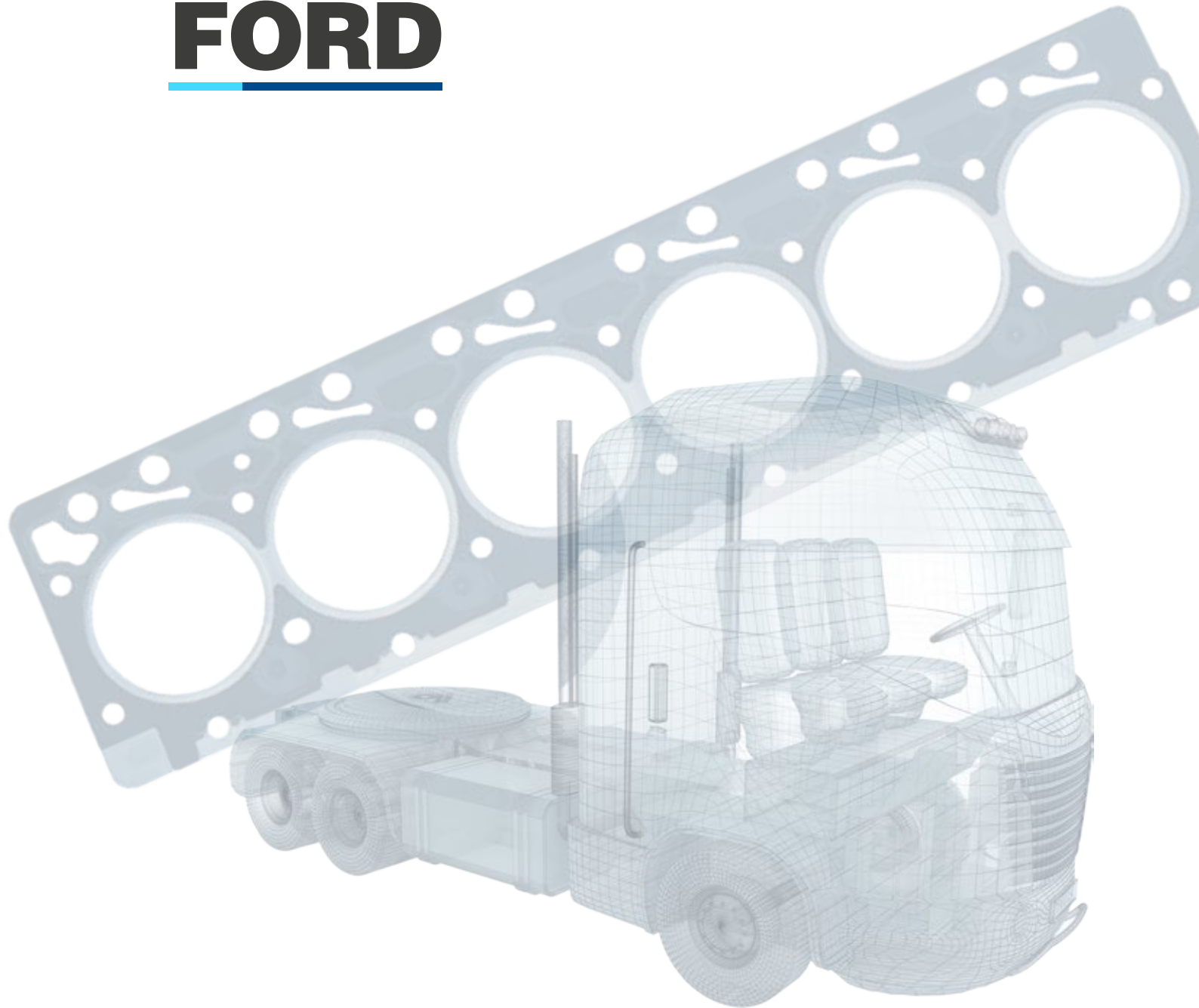

FORD
6.600 / F 4000

N° CORTECO	DESCRIÇÃO DO JOGO
61406ECO	FORD F 4000 MOTOR FNH 268 4 CILS C/ RETENORES

Componentes do Jogo

88024-BO	8
88031-CB	1
88038-AN	1
88036-AN	1
88037-AN	1
88027-BO	1
22886-BO	1
88032-SC	1
88039-SC	1
88033-CB	1
88034-AN	1
88035-AN	1
88041-AN	1
88042-A	2
88025-BO	1
88029-BO	4
88043-CB	1
88026-VI	1
9124P	1
9125S	1
KA-88045	1

Quantidades



KIT ARRUELAS FORD - (TRATORES/CAMINHÕES) KA-88045

6.2 x 9.8 x 1.0mm	7.0 x 10.1 x 1.0mm	8.0 x 11.0 x 1.0mm	9.8 x 18.1 x 1.0mm	9.9 x 17.5 x 1.5mm
10.2 x 13.3 x 1.0mm	19.9 x 26.5 x 2.0mm	19.8 x 25.4 x 1.5mm	11.5 x 17.8 x 1.0mm	23.7 x 31.8 x 2.0mm

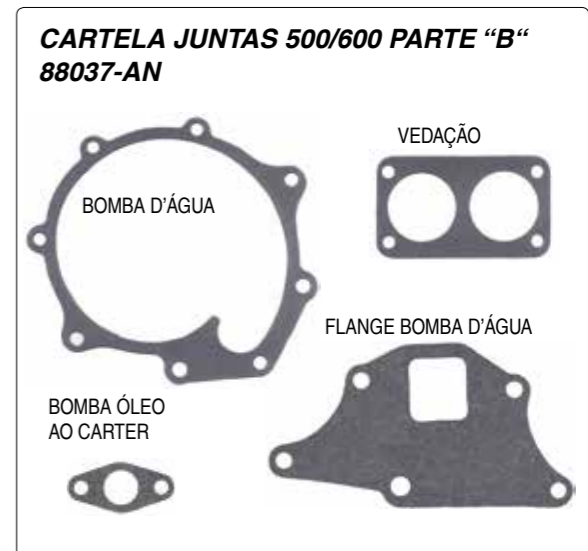
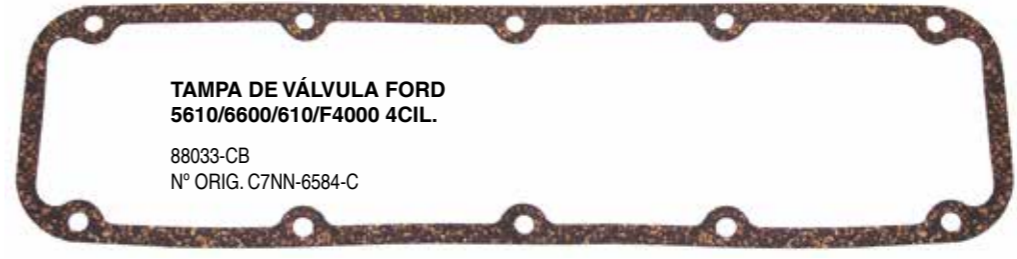
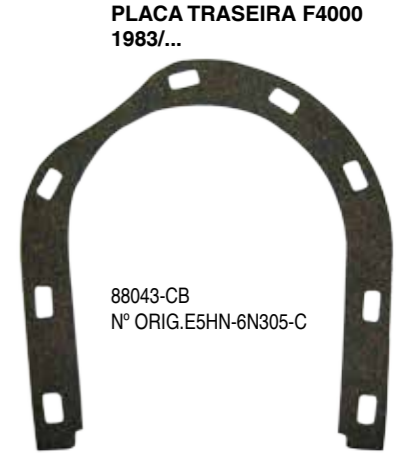
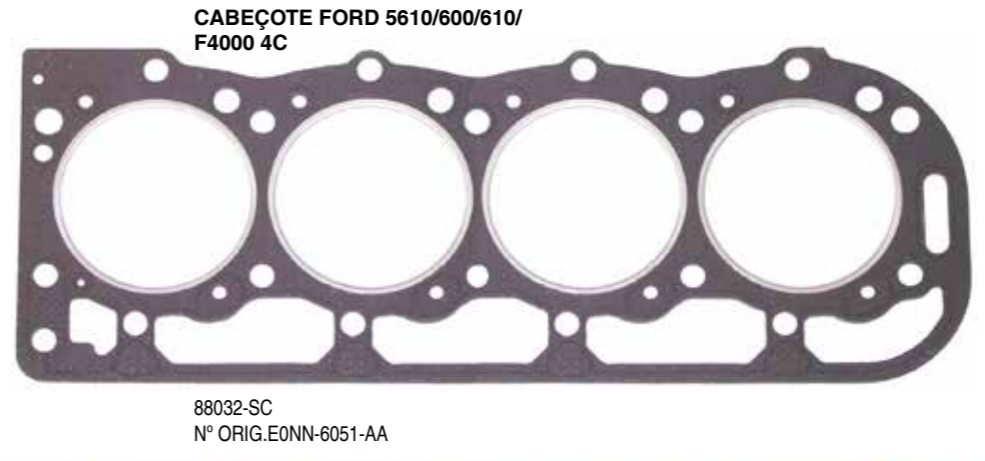

FREUDENBERG-NOK

TECNOLOGIA EM VEDAÇÃO



A Freudenberg - Corteco disponibiliza para o mercado de reposição a linha completa de **RETENTORES**. São componentes originais desenvolvidos em conformidade com as rigorosas exigências internacionais de qualidade das montadoras e das normas ambientais.

www.corteco.com



Divisão de Reposição

Seja original, seja **Freudenberg-NOK**

KITS DE JUNTAS

MAXION / PERKINS

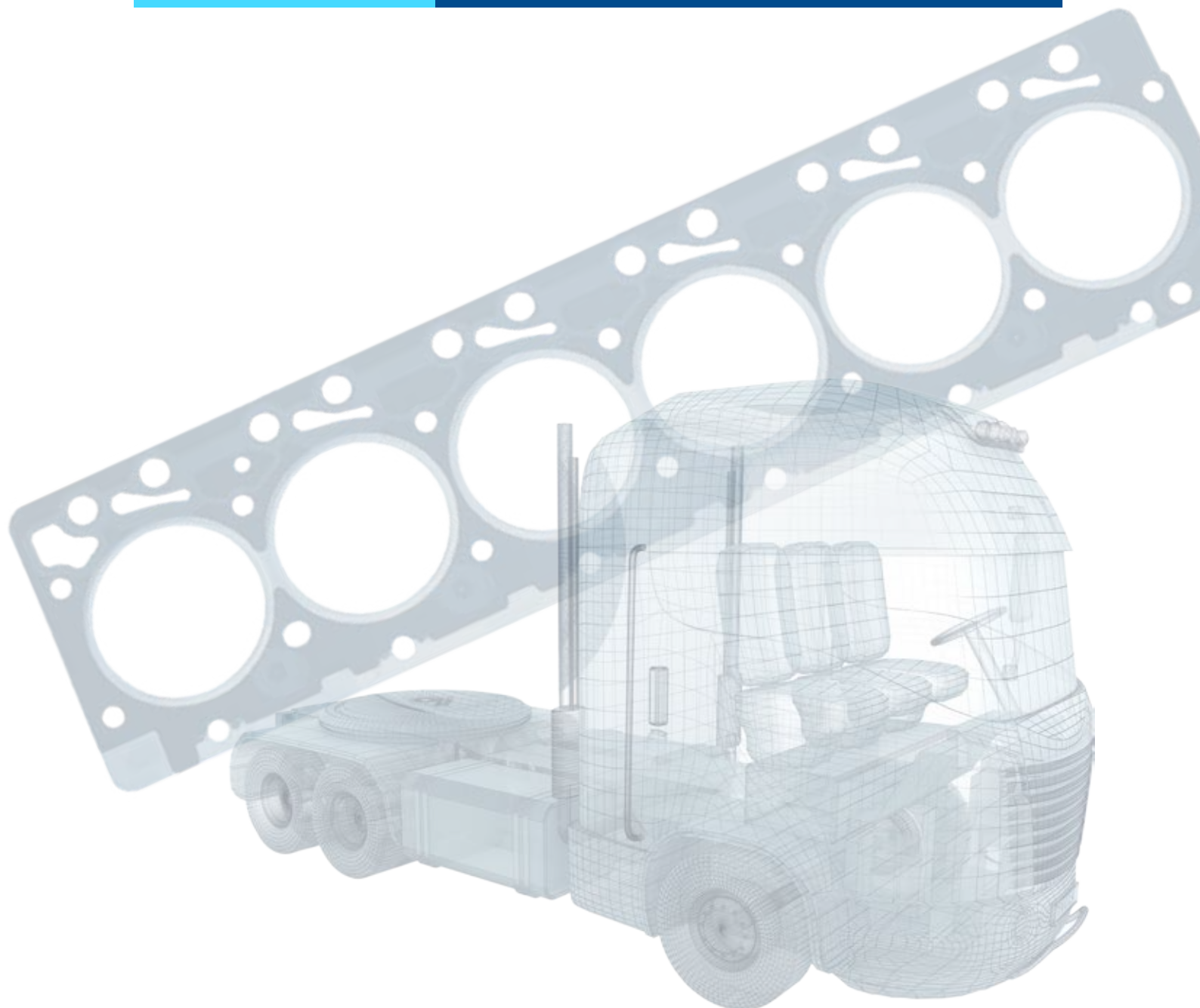

MAXION / PERKINS
4.236 / 4.248 (AGRÍCOLA)

Nº CORTECO	DESCRIÇÃO DO JOGO
70306ECO	PERKINS D 4.236 / 4.248 AGRÍCOLA C/RETENORES

Componentes do Jogo

- 22888-A 2
- 22602-SC 1
- 22604-AN 1
- 22607-CV 2
- 22608-CV 1
- 22609-CV 1
- 22610-CV 1
- 22611-CB 1
- 22612-SC 2
- 22613-AN 1
- 22614-AN 1
- 22891-BO 1
- 22619-CB 1
- 22621-BO 2
- 22648-PP 1
- 22895-A 1
- 313V 1
- 3241V 8
- 9121S 1
- KA-22790 1
- 22598-AN 1
- 22599-AN 1
- 22600-AN 1
- 22601-AN 1
- 22615-CB 1
- 22617-AN 1

Quantidades

PERKINS 4236 22599-AN

TUBO SUÇÇÃO Nº ORIG.70.490.156	TURBINA (SAIDA ÓLEO) Nº ORIG. 36.861.454	CONEXÃO SAÍDA D'ÁGUA Nº ORIG.3.6834.147	FILTRO ÓLEO LUBRIFICANTE Nº ORIG.36.862.155
TAMPA TRASEIRA CABEÇOTE Nº ORIG.36.851.409	CORPÓ BOMBA D'ÁGUA Nº ORIG.38.66.721	BLOCO BALANCEADOR DINAMICO ÓLEO LUBRIFICANTE Nº ORIG.36.87M.006	TERMOSTATO AO CABEÇOTE Nº ORIG.36.853.514

PERKINS 4236 - 22600-AN

CORPO DIANT. AO TRAS. BOMBA D'ÁGUA Nº ORIG.70.490.145	PLACA DE ALIVIO Nº ORIG.36.866.724	ADAPTADOR AO EXAUSTOR Nº ORIG.36.866.416	TAMPA TOMADA DE FORÇA Nº ORIG. 36.835.414	PLACA AO BLOCO Nº ORIG.36.862.523
			JUNTA Nº ORIG.0.490.355	

PERKINS 4236 - 22598-AN

ACIONAMENTO TAQUIMETRO Nº ORIG.36.833.119	CONEXÃO ACIONAMENTO ANGULAR Nº ORIG.36.832.409	BOCAL ABASTECIMENTO Nº ORIG.36.862.138	BOMBA ALIMENTADORA Nº ORIG.36.851.113	FILTRO ÓLEO Nº ORIG.36.862.517
CONEXÃO ENTRADA D'ÁGUA Nº ORIG.36.867.141	FILTRO ÓLEO LUBRIFICANTE Nº ORIG.36.832.002	BOMBA ALIMENTADORA Nº ORIG.36.856.102	ACOPLAMENTO BOMBA INJETORA Nº ORIG. 70.490.063	BOMBA D'ÁGUA Nº ORIG. 70.490.146
				COBERTA RETENTOR Nº ORIG.36.817.157

PERKINS 4236 - 22601-AN

TUBO SUÇÇÃO Nº ORIG.70.490.156	BOMBA INJETORA AO ADAPTADOR Nº ORIG.36.834.143	CARCAÇA TERMOSTATO Nº ORIG.0.490.734	BOMBA INJETORA A CAIXA DISTRIBUIÇÃO Nº ORIG.70.490.100	BLOCO TOMADA DE POTENCIA Nº ORIG. 70.490.210	CAIXA DISTRIBUIÇÃO AO ADAPTADOR EXAUSTOR Nº ORIG.35.86.511
-----------------------------------	---	---	---	---	---

KIT ARRUELAS - KA-22790

6.2 x 9.8 x 1.0mm	8.4 x 11.3 x 1.0mm	10.3 x 15.0 x 1.5mm	16.6 x 21.0 x 1.5mm	10.3 x 21.0mm	13.1 x 18.8 x 2.0mm	19.5 x 27.0 x 1.5mm	22.2 x 28.8 x 2.5mm
-------------------	--------------------	---------------------	---------------------	---------------	---------------------	---------------------	---------------------

CABEÇOTE 4236 VEICULAR/AGRÍCOLA

22602-SC
Nº ORIG.36.81E.021

BOMBA DE ÓLEO

22648-PP
Nº ORIG.36.866.722

TAMPA DISTRIBUIÇÃO 4.236 / 248

22614-AN
Nº ORIG.36.813.137

SAÍDA ESCAPAMENTO 4.236/248

22612-SC
Nº ORIG.36.822.111

CARTER PERKINS 4.236 /248 (AGRÍCOLA)

22604-AN
Nº ORIG.36.815.707

BOMBA D'ÁGUA 4.236/248

22617-AN
Nº ORIG.70.490.146

TARQUIMETRO

22615-CB
Nº ORIG. 33.825.419

CARCAÇA CONEXÃO SUPERIOR

22619-CB
Nº ORIG.36.835.425

VEDADOR 5,0 x 18,0 - PALITO

22621-BO
Nº ORIG.32.811.408

GAXETA MANCAL TRAS.

22888-A
Nº ORIG. 70.730.023

TAMPA DE VÁLVULA 4248 / 4236

22611-CB
Nº ORIG.70.490.149

COLETOR ADMISSÃO TRAS. Q 20 B4236

22609-CV
Nº ORIG.36.88C.001

TRAS. DISTRIBUIDOR 4.236 / 248

22613-AN
Nº ORIG.36.814.127

COLETOR ESCAP. 4.236 /248

22607-CV
Nº ORIG.36.88C.007

COLETOR ADMISSÃO CENTRAL

22608-CV
Nº ORIG.36.88C.002

RETENTOR HASTE VÁLVULAS

3241V

RETENTOR TRASEIRO

9121S

RETENTOR DIANTEIRO

313V

COLETOR ADMISSÃO FRONTAL Q 20 B4236

22610-CV
Nº ORIG.36.88C.003

GAXETA ESCAPAMENTO

22895-A
Nº ORIG.0.490.301

MAXION / PERKINS
4.236 / Q20B (VEICULAR)

Nº CORTECO

DESCRIÇÃO DO JOGO

80185ECO

PERKINS Q20B 4.236 D-10 / D-20 C/RETENORES

Componentes do Jogo

- 22508-BO
- 22602-SC
- 22605-AN
- 22606-CB
- 22607-CV
- 22608-CV
- 22609-CV
- 22610-CV
- 22611-CB
- 22612-SC
- 22613-AN
- 22891-BO
- 22621-BO
- 22623-AN
- 22625-CB
- 22895-A
- 313V
- 3241V
- 306V
- KA-22790
- 22598-AN
- 22599-AN
- 22600-AN
- 22601-AN

- 4
- 1
- 1
- 1
- 2
- 1
- 1
- 1
- 1
- 1
- 1
- 1
- 2
- 1
- 1
- 1
- 1
- 8
- 1
- 1
- 1
- 1
- 1
- 1

PERKINS 4236
22599-AN

TUBO SUÇÃO	TURBINA (SAÍDA ÓLEO)	CONEXÃO SAÍDA D'ÁGUA	FILTRO ÓLEO LUBRIFICANTE
Nº ORIG.70.490.156	Nº ORIG. 36.861.454	Nº ORIG.3.6834.147	Nº ORIG.36.862.155

TAMPA TRASEIRA CABEÇOTE

CORPÓ BOMBA D'ÁGUA

BLOCO BALANCEADOR DINAMICO ÓLEO LUBRIFICANTE

TERMOSTATO AO CABEÇOTE

Nº ORIG.36.851.409	Nº ORIG.38.66.721	Nº ORIG.36.87M.006	Nº ORIG.36.853.514

PERKINS 4236 - 22600-AN

CORPO DIANT. AO TRAS. BOMBA D'ÁGUA

PLACA DE ALIVIO

ADAPTADOR AO EXAUSTOR

TAMPA TOMADA DE FORÇA

PLACA AO BLOCO

Nº ORIG.70.490.145	Nº ORIG.36.866.724	Nº ORIG.36.866.416	Nº ORIG. 36.835.414	Nº ORIG.36.862.523

PERKINS 4236 - 22598-AN

ACIONAMENTO TAQUIMETRO

CONEXÃO ACIONAMENTO ANGULAR

BOCAL ABASTECIMENTO

BOMBA ALIMENTADORA

FILTRO ÓLEO

Nº ORIG.36.833.119	Nº ORIG.36.832.409	Nº ORIG.36.862.138	Nº ORIG.36.851.113	Nº ORIG.36.862.517

CONEXÃO ENTRADA D'ÁGUA

FILTRO ÓLEO LUBRIFICANTE

BOMBA ALIMENTADORA

ACOPLAMENTO BOMBA INJETORA

BOMBA D'ÁGUA

COBERTA RETENTOR

Nº ORIG.36.867.141	Nº ORIG.36.832.002	Nº ORIG.36.856.102	Nº ORIG. 70.490.063	Nº ORIG. 70.490.146	Nº ORIG.36.817.157

PERKINS 4236 - 22601-AN

TUBO SUÇÃO

BOMBA INJETORA AO ADAPTADOR

CARCAÇA TERMOSTATO

BOMBA INJETORA A CAIXA DISTRIBUIÇÃO

BLOCO TOMADA DE POTENCIA

CAIXA DISTRIBUIÇÃO AO ADAPTADOR EXAUSTOR

Nº ORIG.70.490.156	Nº ORIG.36.834.143	Nº ORIG.0.490.734	Nº ORIG.70.490.100	Nº ORIG. 70.490.210	Nº ORIG.35.86.511

KIT ARRUELAS - KA-22790

6.2 x 9.8 x 1.0mm	8.4 x 11.3 x 1.0mm	10.3 x 15.0 x 1.5mm	16.6 x 21.0 x 1.5mm	10.3 x 21.0mm	13.1 x 18.8 x 2.0mm	19.5 x 27.0 x 1.5mm	22.2 x 28.8 x 2.5mm

CABEÇOTE 4236 VEICULAR/AGRICOLA



22602-SC
Nº ORIG.36.81E.021

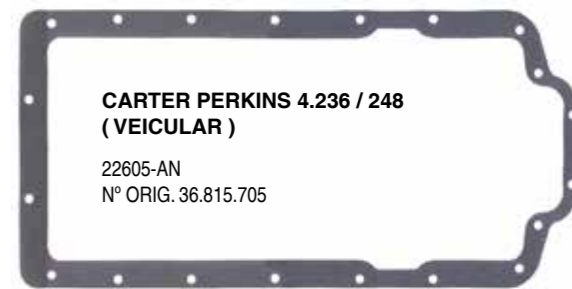

CARTER PERKINS 4.236 / 248 (VEICULAR)

22605-AN
Nº ORIG. 36.815.705

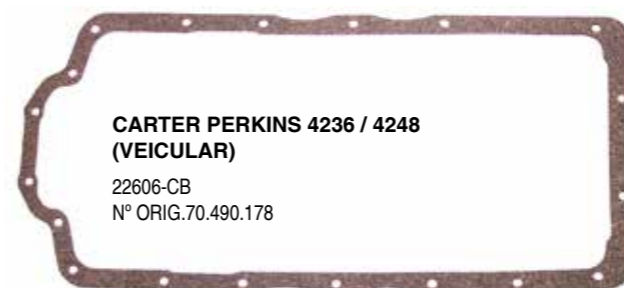

CARTER PERKINS 4236 / 4248 (VEICULAR)

22606-CB
Nº ORIG.70.490.178



TAMPA DISTRIBUIÇÃO 4.236

22623-AN
Nº ORIG.36.813.138

SAÍDA ESCAPAMENTO 4.236/248



22612-SC
Nº ORIG.36.822.111

SAÍDA ESCAPAMENTO PERKINS 4.236 / 248



22612-SC
Nº ORIG.36.822.111



TAMPA DE VÁLVULA 4248 / 4236

22611-CB
Nº ORIG.70.490.149



TRAS. DISTRIBUIDOR 4.236 / 248

22613-AN
Nº ORIG.36.814.127

COLETOR ADM. TRAS. Q20B 4236



22609-CV
Nº ORIG.36.88C.001

COLETOR ADM. FRONTAL Q20B 4236



22610-CV
Nº ORIG.36.88C.003

COLETOR ESCAPAMENTO PERKINS 4.236 / 248



22607-CV
Nº ORIG.36.88C.007

COLETOR ADMISSÃO



22608-CV
Nº ORIG.36.862.133

RETENTOR TRASEIRO



9121S

RETENTOR DIANTEIRO



313V

RETENTOR HASTE VÁLVULAS



3241V

INSPEÇÃO TAQUIMETRO



22625-CB
Nº ORIG.36.825.107

SAÍDA ESCAPAMENTO PERKINS (VEICULAR)



22895-A

**MAXION / PERKINS
S4 / S4T**

Nº CORTECO **DESCRIÇÃO DO JOGO**

70305ECO PERKINS S4T / D-20/ D-40 C/RETENORES

Componentes do Jogo

- 22810-BO
- 22229-AI
- 22853-BO
- 22886-BO
- 22889-BO
- 22603-SC
- 22606-CB
- 22607-CV
- 22608-CV
- 22609-CV
- 22610-CV
- 22891-BO
- 22616-AI
- 22892-BO
- 22624-AN
- 22627-BO
- 22628-BO
- 22633-AN
- 313V
- 3241V
- 9121S
- KA-22787
- 22953-BO
- 22634-AN
- 22635-AN

Quantidades

RETENTOR HASTE VÁLVULAS



3241V

VEDADOR O'RING 4,5 x 1,8



22810-BO

VEDADOR 6,0 x 10,5 x 5,5 - TUBO

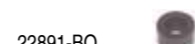

22891-BO
Nº ORIG.33.811.113

VEDADOR O'RING 21,5 x 2,2



22953-BO

VEDADOR PRISIONEIRO TAMPA DE VÁLVULAS S4 / S4T



22892-BO
Nº ORIG.33.817.137

VEDADOR 18,77 x 1,78 NR 2018



22853-BO

VEDADOR 15,6 x 1,8 NR 2016



22886-BO

**KIT ARRUELAS PERKINS S4 / S4T
KA-22787**

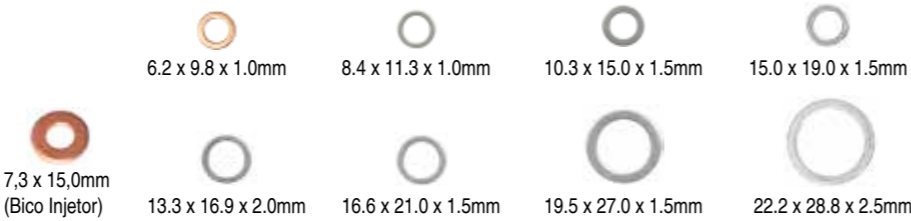

CARTELA S4 / S4T - 22634-AN

SUPORTE BOMBA D'ÁGUA

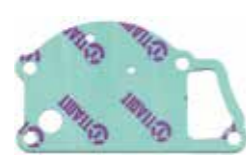

Nº ORIG.70490144

ADAPTADORA BOMBA INJETORA



Nº ORIG.0.490.773

BOMBA DE VÁCUO



Nº ORIG. 36865511

BOMBA D'ÁGUA



Nº ORIG.70490255

JUNTA PESCADOR



Nº ORIG. 70490156

SAÍDA ÓLEO TURBINA



Nº ORIG.36832131

BOMBA ALIMENTADORA



Nº ORIG.36856102

CURVA ADMISSÃO



Nº ORIG.70490257

BOMBA INJETORA



Nº ORIG.36834143

**CARTELA S4 / S4T
22635-AN**

ENTRADA ÓLEO TURBINA



Nº ORIG.70490242

CONEXÃO TERMOSTATO



Nº ORIG.70490254

PESCADOR



Nº ORIG.36832118



TAMPA TRASEIRA
Nº ORIG.36817157

CARCAÇA TERMOSTATO



Nº ORIG.36853514

FILTRO ÓLEO LUBRIFICANTE



Nº ORIG.70490256

TAMPA TRASEIRA DO CABEÇOTE



Nº ORIG.36851409

CABEÇOTE PERKINS S4 / S4T



22603-SC
Nº ORIG.36.81E.016

CARTER PERKINS 4236 / 4248 (VEICULAR)

22606-CB
Nº ORIG.70.490.178



BASE TURBINA (INOX)



22229-AI
Nº ORIG. 344.098.7080

EUXASTOR (S4T)



22616-AI
Nº ORIG.36.88A.004

TAMPA CAIXA DISTRIBUIÇÃO (S4 / S4T)

22633-AN
Nº ORIG.70.490.259



TAMPA DE VÁLVULAS S4 / S4T

22889-BO
Nº ORIG. 70.490.258

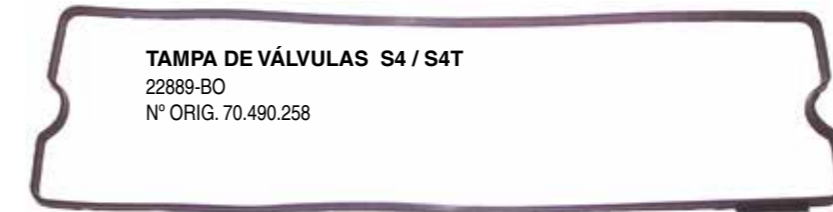

CAIXA DE DISTRIBUIÇÃO (S4 / S4T)

22624-AN
Nº ORIG.36.814.137



COLETOR ADM. TRAS. Q20B 4236



22609-CV
Nº ORIG.36.88C.001

COLETOR ADM. FRONTAL Q20B 4236



22610-CV
Nº ORIG.36.88C.003

COLETOR ESCAPAMENTO PERKINS 4.236 / 248



22607-CV
Nº ORIG.36.88C.007

COLETOR ADMISSÃO



22608-CV
Nº ORIG.36.862.133

RETENTOR TRASEIRO



9121S

RETENTOR DIANTEIRO



313V

VEDADOR TAMPA ÓLEO S4 / S4T



22627-BO
Nº ORIG.70.590.011

VEDADOR TAMPA CAIXA DISTRIBUIDOR S4 / S4T



22628-BO
Nº ORIG.70.590.009

MAXION / PERKINS
6.354 / 6.354-4

Nº CORTECO

DESCRIÇÃO DO JOGO

70206ECO

PERKINS 6.354 TRATOR MF 296 / DODGE D-700 C/ RETENTORES

Componentes do Jogo

22508-BO	6
22562-SC	1
22565-AN	1
22568-AI	2
22569-CV	2
22570-AI	1
22571-CB	1
22572-AN	1
22573-CV	2
22575-CB	3
22576-CB	1
22577-BO	1
22621-BO	2
22636-AN	1
313V	1
9121S	1
3241V	12
KA-22786	1
22559-AN	1
22560-AN	1
22561-AN	1

Quantidades

CARTELA - 22559-AN

TAMPA TRAS. CABEÇOTE ORIG. 0.490.485	TERMOSTATO Nº ORIG. 36861745	FILTRO ÓLEO LUBRIF. Nº ORIG. 33828108	SUORTE EXAUSTOR Nº ORIG. 36866426
TUBULAÇÃO BOMBA ÓLEO Nº ORIG.36832118	JUNTA Nº ORIG.38831115	JUNTA	JUNTA

CARTELA - 22560-AN

BOMBA D'ÁGUA ORIG.36867162	TAMPA TAQUIMETRO Nº ORIG.36866343	FILTRO DE AR Nº ORIG.36825123	BOMBA D'ÁGUA Nº ORIG.36867173
JUNTA	BOMBA ALIMENTORA Nº ORIG.36856102	BOMBA COMBUSTÍVEL Nº ORIG.36851113	FILTRO DE ÓLEO Nº ORIG.36862538
			SUORTE FILTRO ÓLEO Nº ORIG.409321

CARTELA - 22561-AN

CARCAÇA TERMOSTATO Nº ORIG.36846113	TUBO SUCÇÃO BOMBA ÓLEO Nº ORIG.36833136	ADAPTADOR COMPRESSOR Nº ORIG.36821118	BOMBA ÓLEO Nº ORIG.36865532
BOMBA D'ÁGUA Nº ORIG.36866745	BASE FILTRO ÓLEO LUBRIFICANTE Nº ORIG.36866105	SUORTE FILTRO JUNTA	CARCAÇA VEDADOR TRASEIRO Nº ORIG. 36817157

VEDADOR O'RING 17 x 2,5mm



22577-BO

VEDADOR 5,0 x 18,0 - PALITO



22621-BO
Nº ORIG.32.811.408

VEDADOR PORTA INJETOR



22508-BO

BOCAL ÓLEO



22575-CB
Nº ORIG. 36.833.125

COLETOR ESCAPAMENTO EXTREMIDADE



22568-AI
Nº ORIG.36.862.191

COLETOR ESCAPAMENTO (CENTRAL)



22570-AI
Nº ORIG. 36.866.746

COLETOR ADMISSÃO (CENTRAL)



22569-CV
Nº ORIG.70.490.160

COLETOR ADMISSÃO EXTREMOS



22573-CV
Nº ORIG.70.490.161

CABEÇOTE PERKINS 6354.4 6Cils. INOX



22562-SC
Nº ORIG. 36.814.202

TAMPA DE VÁLVULA PERKINS 6.354

22571-CB
Nº ORIG.36.811.438



CARTER PERKINS 6.354

22565-AN
Nº ORIG.36.816.107

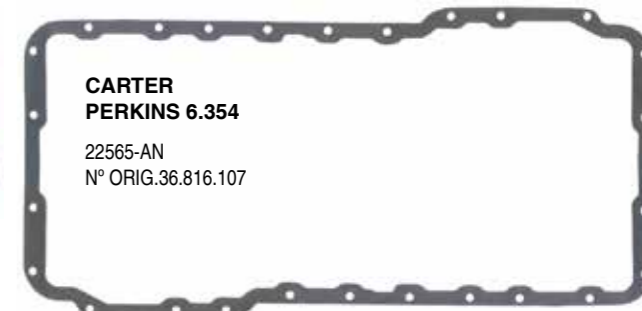

KIT DE ARRUELAS KA-22786



BOMBA D'ÁGUA 6354 Q20B



22636-AN
Nº ORIG.36.867.174

RETENTOR TRASEIRO



9121S

TAMPA DISTRIBUIÇÃO

22572-AN
Nº ORIG. 36.814.124



TAMPA DA INSPEÇÃO

22576-CB
Nº ORIG.36.826.107



RETENTOR HASTE VÁLVULAS



3241V

RETENTOR DIANTEIRO



313V

MAXION / PERKINS
6.357-2

N° CORTECO

DESCRIÇÃO DO JOGO

70906ECO

PERKINS 6.357 6Cils. / F600 / CHEVROLET D 65 C/RETENTOR DA POLIA

Componentes do Jogo

22888-A	2
22511-BO	12
22637-AN	1
22638-AN	1
22639-SC	1
22640 CB	1
22641-SC	3
22642-CB	1
22643-CL	2
22644-AN	1
22645-CB	2
22646-AN	1
22647-SC	1
22895-A	1
8423N	1
KA-22792	1

Quantidades

CARTELA
22638-AN

BOMBA PRIMARIA N° ORIG. 70490135	BOMBA ALIMENTADORA N° ORIG. 70490129	INSPEÇÃO DISTRIBUIÇÃO N° ORIG. 70490083
TAMPA ACIONADOR TAQUIMETRO N° ORIG. 70490024	SUPORTE BOMBA D'ÁGUA N° ORIG. 490736	JUNTA PLACA VEDAÇÃO BLOCO N° ORIG. 490288
SUPORTE BOMBA ALIMENTADORA N° ORIG. 70490111	TAMPA TRASEIRA N° ORIG. 490300	JUNTA N° ORIG. 490245
TAMPA SAÍDA BOMBA ÓLEO N° ORIG. 490245		
TAMPA RETENTOR TRASEIRO N° ORIG. 490263		

CARTELA
22637-AN

TAMPA TAQUIMETRO N° ORIG. 70490026	JUNTA ACOPLAMENTO BOMBA INJETORA N° ORIG. 70490063	TERMOSTATO AO CABEÇOTE N° ORIG. 490676	SUPORTE FILTRO ÓLEO N° ORIG. 70490143	TUBO VAZÃO BOMBA ÓLEO N° ORIG. 70490049
GARGALO ADMISSÃO N° ORIG. 490307	CARCAÇA BOMBA D'ÁGUA N° ORIG. 70490050	SUCÇÃO BOMBA ÓLEO N° ORIG. 70490091	CONEXÃO SUPERIOR SAÍDA D'ÁGUA N° ORIG. 7049063	PLACA BOMBA ALIMENTADORA N° ORIG. 70409136
CONEXÃO SAÍDA D'ÁGUA N° ORIG. 70490071				

KIT ARRUELAS PERKINS - KA-22792

19,5 x 27,0 x 1,5mm	14,5 x 21,0 x 1,5mm	14,5 x 21,0 x 1,5mm	10,5 x 15,9 x 1,0mm	40,1 x 46,8 x 0,8mm	10,3 x 21,0 x 2,0mm	14,5 x 21,0 x 1,5mm

CABEÇOTE PERKINS 6340/ 6354/ 6357V TA

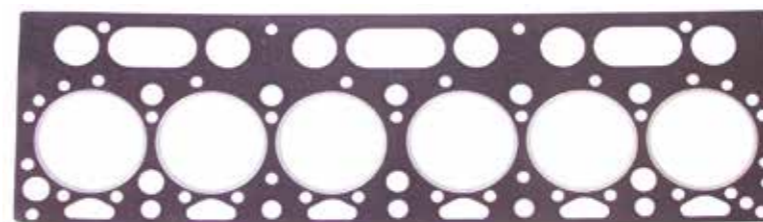

22639-SC
N° ORIG. 70.490.058

COLETOR ADMISSÃO 6.340 / 6.357



22646-AN
N° ORIG. 70.490.087

TAMPA DE VÁLVULAS 6.357 / 340

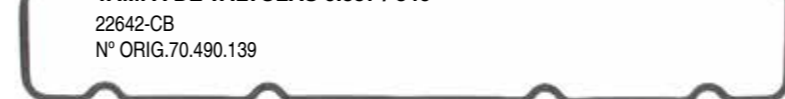

22642-CB
N° ORIG. 70.490.139



CARTER
22640-CB
N° ORIG. 70.490.132

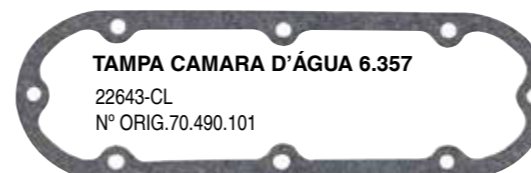

TAMPA CAMARA D'ÁGUA 6.357
22643-CL
N° ORIG. 70.490.101

TAMPA INSPEÇÃO DISTRIBUIDOR



22645-CB
N° ORIG. 70.490.065

COLETOR SAÍDA ESCAPAMENTO



22647-SC
N° ORIG. 00.490.433



TAMPA DISTRIBUIÇÃO PERKINS 6.357
22644-AN
N° ORIG. 70.490.092

COLETOR ESCAPAMENTO PERKINS 6.340 / 357



22641-SC
N° ORIG. 00.490.675

GAXETA MANCAL TRASEIRO



22888-A
N° ORIG. 70.730.023

RETENTOR DIANTEIRO



8423N

SAÍDA ESCAPAMENTO PERKINS 6.340/357 (Veicular)



22895-A
N° ORIG. 0.490.301

MAXION / PERKINS
1006 / 1006-6T

Nº CORTECO **DESCRIÇÃO DO JOGO**

70205ECO MOTOR MAXION 1006 (MF -630/ 640/ 650/ 660) ASP/ TURBO COM RETENTORES

Componentes do Jogo

- 22229-AI 1
- 22509-SI 6
- 22563-SC 1
- 22564-AN 1
- 22566-CB 1
- 22567-SI 1
- 22568-AI 2
- 22569-CV 2
- 22570-AI 1
- 22573-CV 2
- 22574-AN 1
- 22578-AN 1
- 22579-AN 1
- 22580-AN 1
- 22581-AN 1
- 22582-AN 1
- 22583-AN 1
- 22584-AN 1
- 22585-AN 1
- 22586-AN 1
- 22587-AN 1
- 22588-AN 1
- 22589-AN 1
- 22590-AN 1
- 22591-AN 2
- 22592-AN 1
- 22593-AN 1
- 22594-AN 1
- 22595-AN 1
- 22596-AN 1
- 22597-AN 1
- 22618-AN 1
- 22620-AN 1
- 22626-AN 1
- 9121S 1
- 22630-AN 1
- 22631-AN 1
- 22512-AN 1
- 22771-CU 6
- 3241V 12
- 313V 1
- 22622-AN 1

Quantidades

COLETOR ESCAPAMENTO **BOMBA INJETORA** **COLETOR ADMISSÃO EXTREMOS** **BASE TURBINA (INOX)**
PERKINS 6354.4



INSTALAÇÃO TURBO



TERMOSTATO



TUBO ESCAPAMENTO



FILTRO RESPIRO ÓLEO



BOMBA ÓLEO



INSTALAÇÃO TURBINA



RETENTOR TRASEIRO



SAIDA DO ÓLEO



VEDAÇÃO



RETENTOR HASTE VÁLVULAS



VEDAÇÃO



TERMOSTATO



ARRUELA 10,3 x 21,0mm (BICO INJETOR)



VEDADOR PORTA INJETOR 6354.4



RETENTOR DIANTEIRO



CABEÇOTE MAXION 1006-T 6Cils.



22563-SC
Nº ORIG. 36.81H.218

TAMPA DE VÁLVULAS
MAXION MF-630 /640/ 50 /60
22566-CB
Nº ORIG. 36.81C.001

TAMPA DE VÁLVULAS
MAXION MF-630 /640/ 50 /60
22567-SI
Nº ORIG. 36.81C.003

CARTELA 22512-AN



BOMBA INJETORA



Nº ORIG. 0.490.773

TAMPA TOMADA DE FORÇA



Nº ORIG. 36.87H.005

TAMPA DA INSPEÇÃO



Nº ORIG. 36.82H.003

COBERTA RETENTOR
4.236 / 248 / 6.354
Nº ORIG. 36.817.157

TERMOSTATO



22586-AN
Nº ORIG. 36.86A.004

BOMBA ALIMENTADORA



22618-AN
Nº ORIG. 36.851.113

BOMBA ALIMENTADORA



22620-AN
Nº ORIG. 36.856.102

TERMOSTATO / CARÇAÇA



22590-AN
Nº ORIG. 36.83N.004

COLETOR ESCAPAMENTO CENTRAL



22570-AI
Nº ORIG. 36.866.746

FILTRO DE ÓLEO



22583-AN
Nº ORIG. 36.87 Y.002

FILTRO ÓLEO RESPIRO



22584-AN
Nº ORIG. 36.87W.003



CARÇAÇA AO BLOCO
22580-AN
Nº ORIG. 36.817.181

COLETOR ADMISSÃO CENTRAL



22569-CV
Nº ORIG. 70.490.160

FILTRO DE ÓLEO



22574-AN

FILTRO ÓLEO RESPIRO



22585-AN
Nº ORIG. 36.86A.511

BOMBA D'ÁGUA



22587-AN
Nº ORIG. 33.82P.004

TERMOSTATO / CARÇAÇA



22582-AN
Nº ORIG. 36.85R.005



TERMOSTATO CARÇAÇA
22581-AN
Nº ORIG. 36.85F.005

VEDAÇÃO



22631-AN

MAXION / PERKINS
HS-2.5 / HS-2.8

N° CORTECO **DESCRIÇÃO DO JOGO**

80325ECO MOTOR MAXION HS-2.5/2.8 P/MB SPRINTER SEM CABEÇOTE COM RETENORES

Componentes do Jogo

22015-AN	1
22849-BO	1
3147V	8
22510-BO	2
KA-22797	1
22513-CB-LT	1
22514-SC	1
22890-BO	1
22515-AN	1
22516-AN	1
22517-AN	1
22518-AN	1
22519-AN	1
22520-AN	1
22521-AN	1
22522-AN	1
22523-AN	1
22524-AN	1
22525-AN	1
22526-AN	1
22527-AN	1
22558-BO	1
7586T	1
7767V	1
9114V	1
9113N	1
IL-22926	19
IL-22927	6

Quantidades

VEDADOR TAMPA ENCHIMENTO ÓLEO - MAXION HS-2.5/2.8



22558-BO
N° ORIG. ERR-4685

RADIADOR ÓLEO



22015-AN

VEDADOR VÁLVULA ALIVIO BOMBA ÓLEO 23 x 3



22849-BO

RETENTOR EIXO COMANDO



9114V

RETENTOR HASTE VÁLVULAS



3147V

VEDADOR DO MANCAL



22510-BO

ARRUELA LIMITADORA DE TORQUE



IL-22926

PINO LIMITADOR DE TORQUE



IL-22927

RETENTOR GUARDA PÓ DISTRIBUIÇÃO



9113N

RETENTOR ÁRVORE DIANTEIRO



7767V

BOMBA DE COMBUSTÍVEL MAXION HS-2.5/2.8



22518-AN
N° ORIG. ERR-2028

DRENO DO ÓLEO MAXION HS-2.5/2.8



22525-AN
N° ORIG. ERR-1653

TAMPA INSPEÇÃO DISTRIBUIÇÃO MAXION HS-2.5/2.8



22521-AN
N° ORIG. ERR-1561

RETENTOR TRASEIRO



7586T

KIT ARRUELAS MAXION HS-2.5 KA-22797

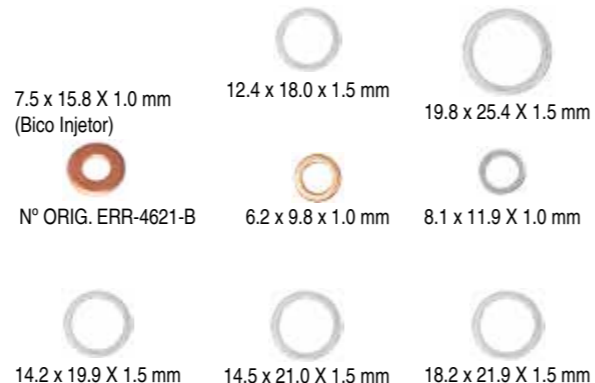

TAMPA DE VÁLVULAS MAXION HS-2.5



22890-BO
N° ORIG. ERR-2409

COL. ADM/ ESCAP. MAXION HS-2.5/2.8



22514-SC
N° ORIG. ERR-3785

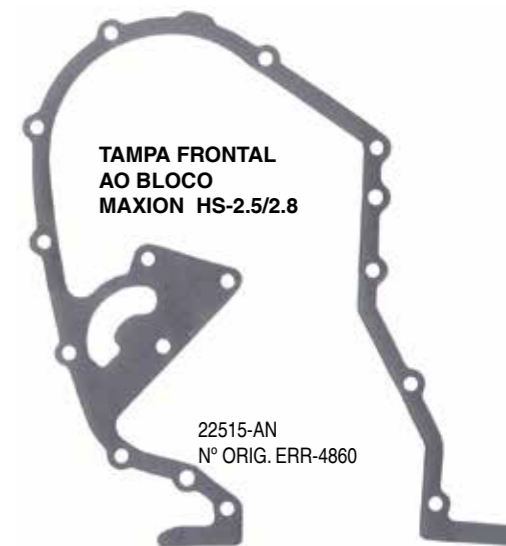

BOMBA D'ÁGUA AO BLOCO MAXION HS-2.5/2.8



22520-AN
N° ORIG. ERR-2378

CARCAÇA BOMBA D'ÁGUA MAXION HS-2.5/2.8



22517-AN
N° ORIG. ERR-3284

BOMBA INJETORA MAXION HS2.5/2.8



22526-AN

TAMPA RETENTOR TRASEIRO



22527-AN
N° ORIG. ERR-4861

CABEÇOTE FILTRO



22522-AN
N° ORIG. ERR-2026

BOMBA DE VÁCUO MAXION HS-2.5/2.8



22523-AN
N° ORIG. ERR-2027

TERMOSTATO MAXION HS-2.5/2.8



22519-AN
N° ORIG. ERR-3490

FILTRO DE ÓLEO MAXION HS-2.5/2.8



22524-AN
N° ORIG. ERR-3283

ITENS AVULSOS

MAXION / PERKINS

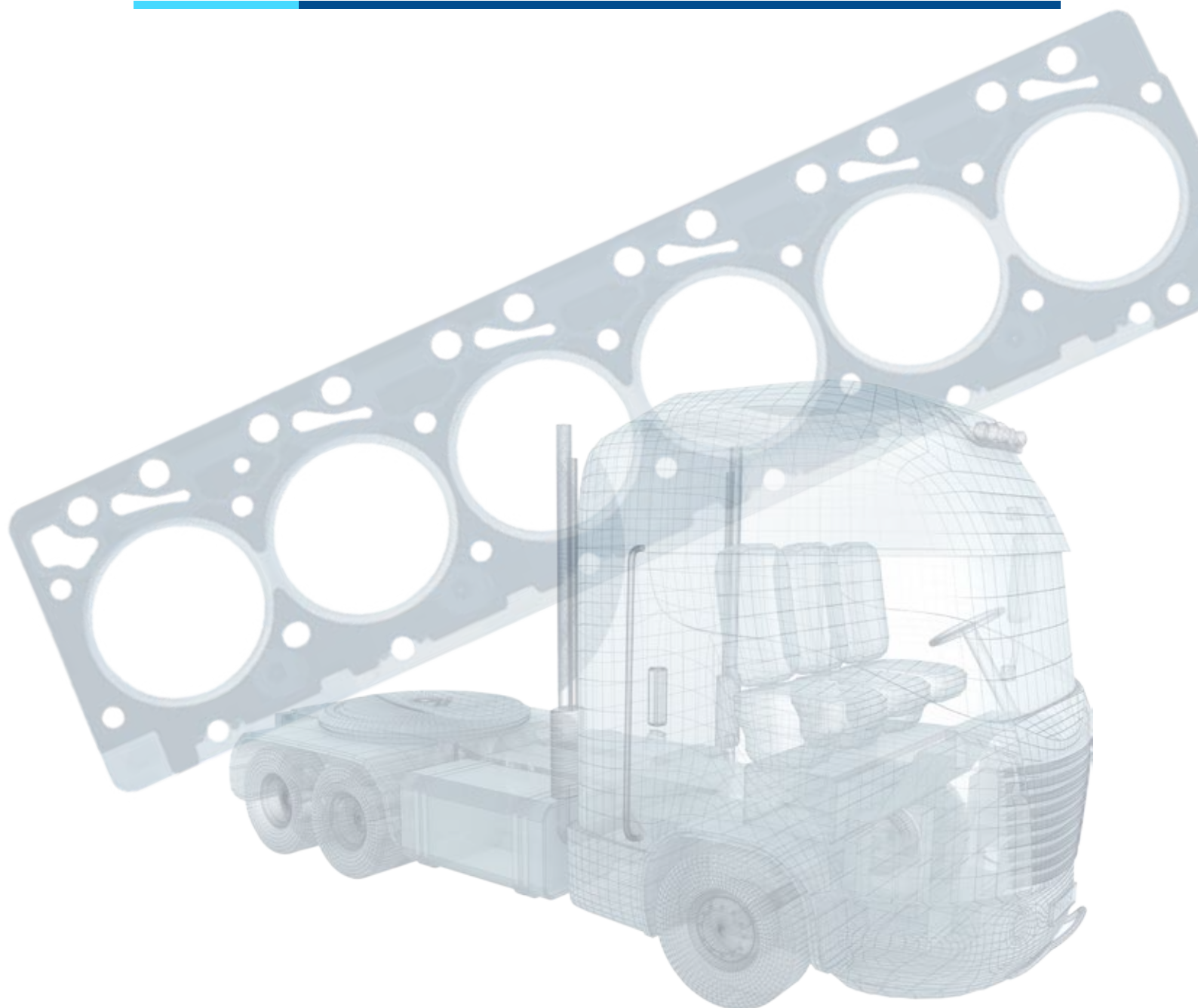

**MAXION / PERKINS
AVULSOS**

N° CORTECO APLICAÇÃO

70306ECO PERKINS D 4.236 / 4.248 AGRÍCOLA

CABEÇOTE 4236 Veicular/Agrícola



82240ECO-SC
N° ORIG.36.81E.021

CARTER PERKINS 4.236 /248 (AGRÍCOLA)
70316ECO-AN
N° ORIG.36.815.707



TAMPA DE VÁLVULA 4248 / 4236

70326ECO-CB
N° ORIG.70.490.149

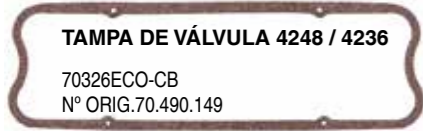

N° CORTECO APLICAÇÃO

80185ECO PERKINS Q20B 4.236 D-10 / D-20

CABEÇOTE 4236 VEICULAR/AGRÍCOLA



82240ECO-SC
N° ORIG.36.81E.021

CARTER PERKINS 4.236 / 248 (VEICULAR)

70216ECO-AN
N° ORIG. 36.815.705



TAMPA DE VÁLVULA 4248 / 4236
70326ECO-CB
N° ORIG.70.490.149



N° CORTECO APLICAÇÃO

80325ECO MOTOR MAXION HS-2.5/2.8 P/MB SPRINTER

TAMPA DE VÁLVULAS MAXION HS-2.5



75325ECO-BO
N° ORIG. ERR-2409

CARTER MAXION HS-2.5/2.8 SPRINTER

70115ECO-CB-LT



N° CORTECO

70906ECO

APLICAÇÃO

PERKINS 6.357 6Cils. / F600 / CHEVROLET D 65

CABEÇOTE PERKINS 6340/ 6354/ 6357V TA



70901ECO-SC
N° ORIG.70.490.058

CARTER

70716ECO-CB
N° ORIG.70.490.132



TAMPA DE VÁLVULAS 6.357 / 340

70826ECO-CB
N° ORIG.70.490.139

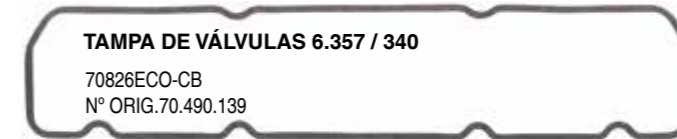

APLICAÇÃO

MOTOR MAXION HS-2.5L MB SPRINTER / FORD RANGER / GM S10 / BLAZER

CABEÇOTE MAXION HS-2.5 1,59mm



82270ECO-SC
N° ORIG. ERR-5263

JUNTA DO CABEÇOTE 1,59mm

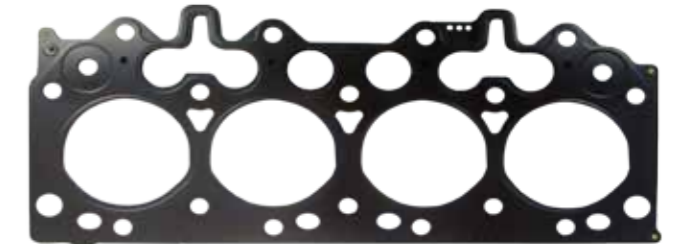

70101ECO-ML

JUNTA DO CABEÇOTE 1,48mm



70102ECO-SC

JUNTA DO CABEÇOTE 1,37mm



70103ECO-SC

APLICAÇÃO

MWM INT HS 2,5L - MB 310 D / 312 D / SPRINTER C / M F 312 D SPRINTER M

JUNTA DO CABEÇOTE



70101ECO-ML

FREUDENBERG-NOK

TECNOLOGIA EM VEDAÇÃO

A Freudenberg - Corteco disponibiliza para o mercado de reposição a linha completa de **COXINS**. São componentes originais desenvolvidos em conformidade com as rigorosas exigências internacionais de qualidade das montadoras e das normas ambientais.

www.corteco.com



Divisão de Reposição

Seja original, seja Freudenberg-NOK

KITS DE JUNTAS

MERCEDES-BENZ

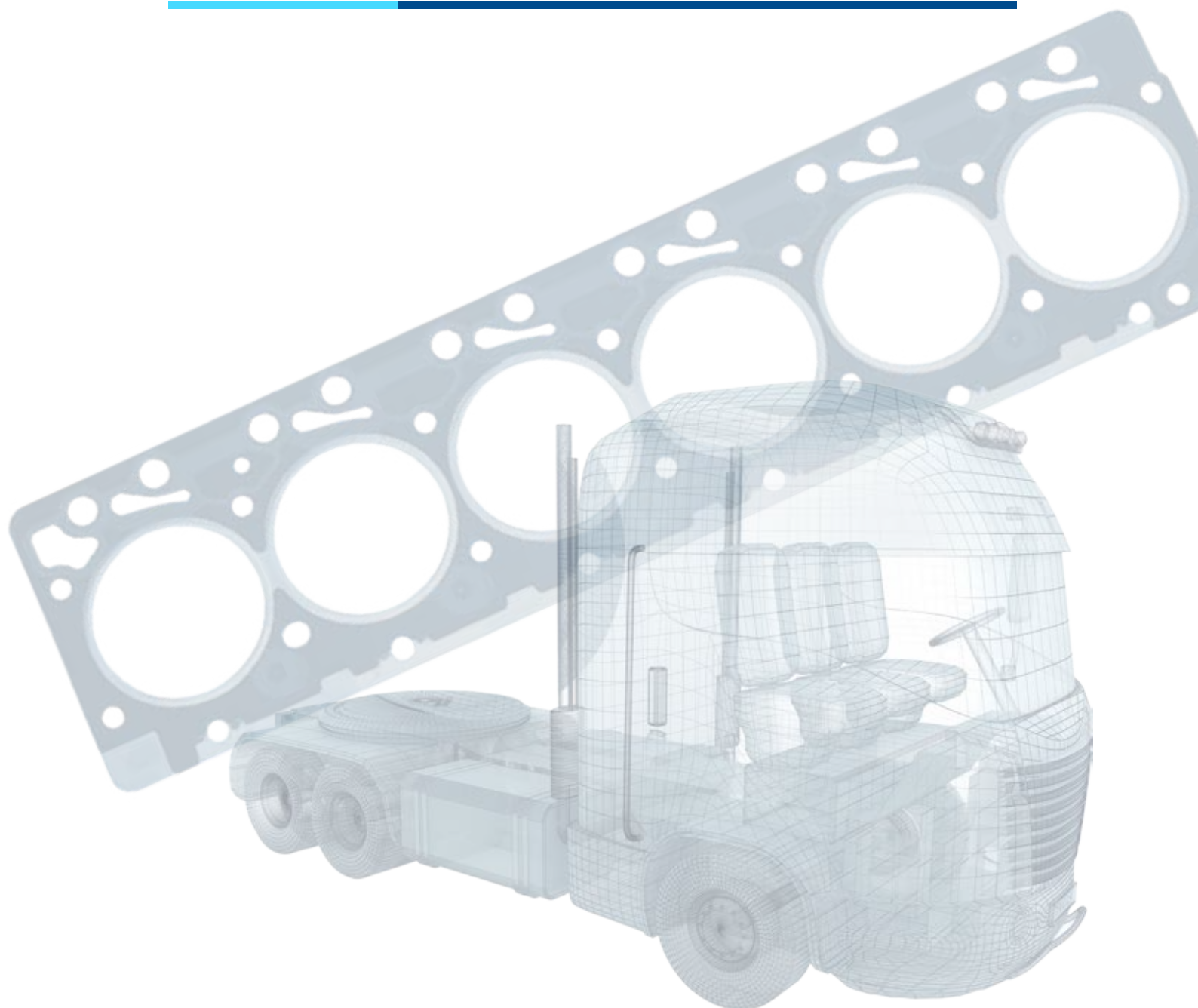

MERCEDES-BENZ
OM 314 / 324

N° CORTECO	DESCRIÇÃO DO JOGO
48306ECO	MERCEDES OM 314 4 CILS.C/ RETENTOR / GAXETA C/ CABEÇOTE 100mm INOX

Componentes do Jogo

Componentes	Quantidades
33216-SC	1
33218-CL	1
33220-SC	1
33221-CB	1
33223-SC	1
33225-FF	1
33219-CL	1
33215-AN	1
KB-33935	1
33282-BO	2
33006-CL	1
33009-CB	1
33013-CB	1
33014-AN	1
33832-A	2
33289-AN	1
33818-CU	1
1174V	1

KIT DE BORRACHAS KB-33935

JOGO CARTER 33020-CL

33218-CL

EXTREMIDADE DIANTEIRA/TRASEIRA 33282-BO

LATERAL ESQUERDO CARTER RETA 33219-CL

TAMPA LATERAL VÁLVULA OM 314/324

33221-CB
N° ORIG.314.015.0622

CABEÇOTE 314/324/364 (INOX)

33216-SC
N° ORIG.314.016.0220

COLETOR ESCAPAMENTO - OM 314

33220-SC
N° ORIG.314.142.0180

CARTELA DE JUNTAS OM314 33215-AN

TAMPA REFRIGERADOR ÓLEO OM 314/324
N° ORIG. 342.015.0080

CARCAÇA BOMBA D'ÁGUA
N° ORIG. 352.201.0480

CABEÇOTE COMPRESSOR
N° ORIG.322.313.0079

<p>CAVALETE D'ÁGUA N° ORIG. 352.203.0680</p>	<p>TUBULAÇÃO D'ÁGUA N° ORIG.071511022006</p>	<p>TERMOSTADO "PEQUENA" N° ORIG. 352.203.0480</p>
<p>TUBO SUCÇÃO N° ORIG. 314.016.0280</p>	<p>TERMOSTADO "MÉDIA" N° ORIG. 352.203.0780</p>	<p>TERMOSTATO "GRANDE" N° ORIG.352.203.0080</p>

<p>TAMPA DE VÁLVULA - OM 324/TOYOTA BANDEIRANTE</p> <p>33223-SC N° ORIG. 314.016.0121</p>	<p>SAÍDA ESCAPAMENTO OM 314</p> <p>33225-FF N° ORIG.715.106.0004</p>	<p>TAMPA INFERIOR DISTRIBUIÇÃO OM 352/352 A</p> <p>33009-CB N° ORIG.312.015.0680</p>		
<p>TAMPA BOMBA D'ÁGUA OM 314/352/352A</p> <p>33014-AN N° ORIG.352.201.0980</p>	<p>TAMPA DISTRIBUIÇÃO OM 314/1321/352/352A</p> <p>33006-CL N° ORIG.352.015.0320</p>	<p>GAXETA</p> <p>33832-A</p>	<p>TUBO ÓLEO</p> <p>33013-CB</p>	<p>RETENTOR DIANTEIRO</p> <p>1174V</p>

CARTELA JUNTAS 33289-AN

<p>FILTRO ÓLEO</p> <p>N° ORIG.314.184.0379</p>	<p>BOMBA INJETORA</p> <p>N° ORIG.312.076.0279</p>	<p>TAMPA DISTRIBUIDOR OM 314/1321/ 352/352A</p> <p>N° ORIG.312.015.0580</p>
<p>FILTRO ÓLEO</p> <p>N° ORIG.327.184.0280</p>	<p>FLANGE BOMBA ALIMENTADORA</p> <p>N° ORIG.000.091.0580</p>	<p>BOMBA D'ÁGUA - ANEL</p> <p>N° ORIG.352.021.10.80</p>
		<p>CAMISA COMPRESSOR</p> <p>N° ORIG.321.131.0079</p>

KIT ARRUELAS - OM 314 33818-CU

8,2 x 13,9 x 1,0mm	20,0 x 24,0 x 1,5mm	16,3 x 19,9 x 1,5mm	26,5 x 31,9 x 2,7mm	26,4 x 31,8 x 2,0mm	9,6 x 20,6 x 1,0mm	ARRUELA DUPLA RETORNO ÓLEO

MERCEDES-BENZ
OM 364

N° CORTECO	DESCRIÇÃO DO JOGO
80364ECO	MERCEDES OM 364 4 CILS. C/ CABEÇOTE 100mm INOX C/RETENTOR
21740ECO	MERCEDES OM 364 4 CILS. TURBINADO C/RETENTOR CABEÇOTE

Componentes do Jogo

33817-CV	1
33217-SC	1
33218-CL	1
33219-CL	1
33222-AN	1
33226-BO	5
33227-AN	1
33821-BO	3
33233-AN	1
33234-CV	1
33244-SC	2
33249-BO	1
33253-SC	1
33258-SC	1
33282-BO	2
33283-CV	3
33284-AN	1
33103-AN	2
33825-BO	1
33009-CB	1
33832-A	2
33833-BO	4
33017-SC	1
33292-AN	1
33371-AN	1
1174V	1
33721-AN	1
KA-33783	1
33769-AL	2
33278-AN	1
33279-AN	1
33216-AN	1

Quantidades

CARTELA JUNTAS OM-364/366
33279-AN



TAMPA DISTRIBUIÇÃO
N° ORIG.352.015.0320

CARCAÇA BOMBA D'ÁGUA



N° ORIG.352.201.0480

CAVALETE D'ÁGUA



N° ORIG.352.203.0680

TUBO ENCHIMENTO ÓLEO



N° ORIG.346.018.0080

TERMOSTATO



N° ORIG.366.203.0080

RETENTOR ARVORE MANIVELA



1174V

VEDADOR O'RING 119 x 3,00



33825-BO

TAMPA INSPEÇÃO DISTRIBUIÇÃO OM 352/352A



33009-CB
N° ORIG.312.015.0680

JUNTA DA TURBINA



33234-CV

GAXETA



33832-A
KA-032 KIT ARRUELAS MMB

BOMBA D'ÁGUA OM 352A/362/364/366



33292-AN
N° ORIG. 352.201.1280

FILTRO RADIADOR ÓLEO

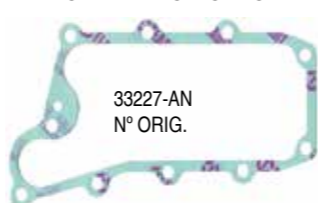

33227-AN
N° ORIG.

RETENTOR ÓLEO MWM TD 229 4/6Cils.



33721-AN

LIGAÇÃO TURBINA OM 364



33371-AN
N° ORIG. 6.232.0852.0044

FILTRO RADIADOR ÓLEO



33103-AN

VEDADOR - 8,0 x 2,5



33821-BO
20,0 x 24,0 x 1,5mm

ARRUELA



33769-AL

VEDADOR 6,0 x 14,0 x 7,5



33226-BO

ENTRADA ÓLEO TURBINA OM 364



33233-AN

VEDADOR 30,8 x 3,7 OM 314/352/352A/355



33833-BO

CABEÇOTE MBB 314/324/364 (INOX)

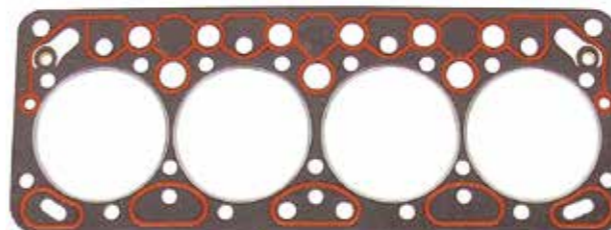

33216-SC
N° ORIG.314.016.0220

CABEÇOTE MBB OM 364

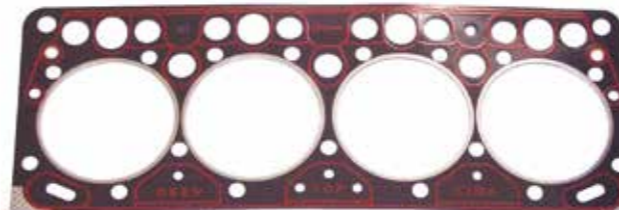

33217-SC
N° ORIG. 364.016.0320

VEDADOR TAMPA LATERAL OM - 364 4CILS.

33249-BO
N° ORIG.364.015.0160

TAMPA REFRIGERADOR ÓLEO - OM 314/324

33222-AN
N° ORIG. 342.015.0080

CARTELA JUNTAS OM-364/366

FLANGE FILTRO ÓLEO



FIXAÇÃO REFRIGERADOR ÓLEO



N° ORIG.312.188.1579

BOMBA INJETORA



N° ORIG.312.076.0279

CAMISA COMPRESSOR



FLANGE BOMBA ALIMENTADORA



N° ORIG.321.131.0079

TAMPA TRASEIRA DISTRIBUIÇÃO



N° ORIG.343.015.0080

JOGO CARTER

LATERAL DIREITO CARTER CURVA 33219-CL



EXTREMIDADE DIANTEIRA/TRASEIRA

33282-BO

LATERAL ESQUERDO CARTER RETA

33218-CL

TAMPA DE VÁLVULAS OM-364 4CILS.

33253-SC
N° ORIG.364.016.0021

TUBO SAÍDA ESCAPAMENTO OM 364



33258-SC

COLETOR ESCAPAMENTO OM 364/366



33283-CV
N° ORIG.366.142.0180

CABECOTE COMPRESSOR OM 314/352/ A /355



33017-SC
N° ORIG.352.131.0380

COLETOR ADMISSÃO TURBINA OM- 364



33284-AN
N° ORIG.321.131.0079

JUNTA TURBINA



33817-CV

COLETOR ADMISSÃO OM 364/366



33244-SC
N° ORIG.366.141.0380

KIT DE ARRUELAS KA-33783



MERCEDES-BENZ
OM 352 / 352A

N° CORTECO

DESCRIÇÃO DO JOGO

33180ECO	MERCEDES OM 352A C/RETENTOR/CABEÇOTE100mm INOX /LAT. BORRACHA
48906ECO	MERCEDES OM 352A 6 CILS. C/RETENTORES / CABEÇOTE 100 m INOX
48806ECO	MERCEDES OM 352 6 CILS. C/RETENTOR / GAXETA / CABEÇOTE 100mm INOX

Componentes do Jogo

33228-CV	1	1
33230-AN	1	1
33231-AN	1	1
33232-CI	1	1
33280-OR	1	1
33282-BO	2	2
33104-AN	1	1
33285-BO	1	1
33286-PP	1	1
33830-BO	1	1
33001-CL	1	1
33002-CL	1	1
33003-CV	2	2
33004-FF		2
33006-CL	1	1
33008-CB	1	1
33009-CB	1	1
33010-PP	1	1
33011-PP	1	1
33012-SC	1	1
33013-CB	1	1
33014-AN	1	1
33016-FF	1	1
33831-CU	1	1
33832-A	2	2
33017-SC	1	1
33306-FF	1	1
1174V	1	1
33289-AN	1	1
33290-AN	1	1
KB-33936	1	1
33761-AL	4	4
33764-AL	4	4
33819-BO	1	1
33226-BO	7	7
33820-BO	1	1
33821-BO	1	1
33893-BO	1	1
33833-BO	6	6
33834-BO	1	1
33835-BO	1	1
33836-BO	1	1

Quantidades

CARTELA JUNTAS - 33289-AN

TAMPA DISTRIBUIDOR



N° ORIG.312.015.0580

BOMBA D'ÁGUA - ANEL



N° ORIG.352.021.10.80

FILTRO ÓLEO



N° ORIG.314.184.0379

CAMISA COMPRESSOR



N° ORIG.321.131.0079

BOMBA INJETORA

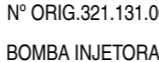

N° ORIG.312.076.0279

RETENTOR TUBO ÓLEO



1174V

33013-CB

KIT DE BORRACHAS KB-33936

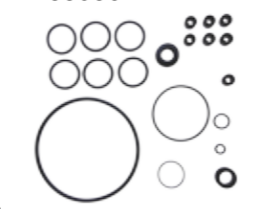

CARTELA DE JUNTAS - 33290-AN

BOMBA D'ÁGUA



N° ORIG.352.201.1280

TERMOSTATO "MÉDIA"



N° ORIG. 352.203.0780

CARCAÇA BOMBA D'ÁGUA



N° ORIG. 352.201.0480

TERMOSTATO "PEQUENA"



N° ORIG. 352.203.0480

JUNTA DA TURBINA



N° ORIG.322.131.0079

CABEÇOTE COMPRESSOR



N° ORIG.352.203.0080

TERMOSTATO "GRANDE"



N° ORIG.352.203.0080

CAVALETE D'ÁGUA



N° ORIG.352.203.0680

TUBULAÇÃO D'ÁGUA



N° ORIG.071511022006

MEDIDOR ÓLEO



N° ORIG.352.018.0380

KIT ARRUELAS

352/352A/366

33831-CU

ARRUELA DUPLA RETORNO ÓLEO	10,2x14,0x1,0mm	14,2x19,9x1,5mm	14,6x17,9x1,5mm
	8,2 x 13,9 x 1,0mm	8,3 x 11,9 x 1,0mm	22,2x27,8x1,5mm
	18,2 x 21,9 x 1,5mm	24,4 x 31,6mm	24,3x28,6x2,0mm
	9,6x20,6x1,0mm	16,4 x 21,9 x 1,5mm	18,2 x 23,9 x 1,5mm
			26,4x31,8x2,0mm

VEDADOR 14,2x19,9x1,5mm

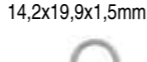

33761-AL

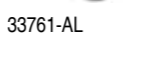

VEDADOR 16,4 x 21,9 x 1,5mm

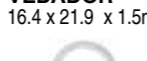

33764-AL

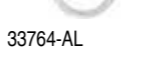

VEDADOR 6,0 x 14,0 x 7,5

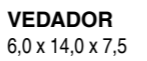

33226-BO

VEDADOR 12,4 x 2,6mm

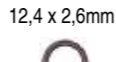

33819-BO

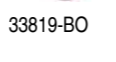

VEDADOR 13,5 x 23,0 x 7,0

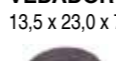

33820-BO

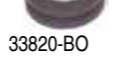

VEDADOR 8,0 x 2,5

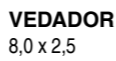

33821-BO

BOMBA D'ÁGUA



33291-AI-AN

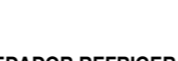

VEDADOR REFRIGER. ÓLEO 64 x 2,5



33893-BO

N° ORIG.2.413.682

JOGO CARTER L 321/OM 352/366 6Cils. 33021-CL



LATERAL DIREITA CARTER CURVA 33002-CL

EXTREMIDADE DIANT/TRAS. 33282-BO

LATERAL ESQUERDA CARTER RETA 33001-CL

JOGO REFRIGERAÇÃO ÓLEO OM 352/352A/321



CAMARA REFRIGERADOR ÓLEO

N° ORIG.044.586.0018

33011-PP

N° ORIG.321.188.01.79

TAMPA REFRIGERADOR ÓLEO

33010-PP

N° ORIG.312.188.14.79

TAMPA LATERAL VÁLVULAS OM 352/352A/321

33008-CB
N° ORIG.352.015.0122

TAMPA DISTRIBUIÇÃO OM 314/321/352/352A



33006-CL
N° ORIG.352.015.0320

TAMPA DISTRIBUIÇÃO OM 364 / 366



33104-AN
N° ORIG.352.015.0320

JUNTA DA TURBINA



33230-AN

JUNTA DA TURBINA



33231-AN

GAXETA



33832-A
N° ORIG. 000.997.9641

SAÍDA ESCAPAMENTO OM 352A



33306-FF
N° ORIG.344.492.0080

CABEÇOTE COMPRESSOR OM 314/352/ A /355



33017-SC
N° ORIG.352.131.0380

SAÍDA ESCAPAMENTO OM 324/352/I 321



33016-FF
N° ORIG.312.492.1080

COLETOR ESCAPAMENTO OM 352A (TURBINADO)



33003-CV
N° ORIG.352.142.0080

COLETOR ESCAPAMENTO (ASPIRADO)



33004-FF
N° ORIG. 322.142.0580

VEDADOR FILTRO ÓLEO



33834-BO

VEDADOR 115,0 x 125,0 x 5,0



33836-BO

TAMPA BOMBA D'ÁGUA OM 314/352/352A



33014-AN
N° ORIG.352.201.0980

TPA INSPEÇÃO DISTRIB. OM 352/352A



33009-CB
N° ORIG.312.015.0680

BASE TURBINA (COBRE) OM 352A/F-1000/D-20



33232-CI
N° ORIG. 352.098.0280

LATERAL TURBINA OM 352A/F-1000/D-20



33228-CV
N° ORIG. 352.098.0880

MERCEDES-BENZ
OM 366 / 366 A

N° CORTECO

DESCRIÇÃO DO JOGO

80270ECO	MERCEDES OM 366A/LA TURBINADO ASPIRADO C/RET. / GAXETA C/CABEÇOTE 100mm INOX
48606ECO	MERCEDES OM 366 ASPIRADO C/RET. / GAXETA C/CABEÇOTE 98,5mm

Componentes do Jogo

33224-AN	1
33228-CV	1
33230-AN	1
33232-CI	1
33233AN	1
33244-SC	3
33248-AN	1
33271-AN	2
33281-OR	1
33282-BO	2
33283-CV	4
33284-AN	4
33103-AN	1
33285-BO	2
33286-PP	1
33105-SC	1
33106-FF	1
33107-AN	1
33001-CL	2
33002-CL	2
33009-CB	1
33010-PP	1
33278-AN	1
33279-AN	1
33831-CU	1
33832-A	1
33017-SC	2
33288-AN	1
33291-AI-AN	1
1174V	1
33721-AN	1
33761-AL	1
KB-33939	1
33819-BO	1
33226-BO	7
33820-BO	7
33826-BO	1
33821-BO	1
33827-BO	2
33828-BO	2
33829-BO	2
33833-BO	2
33835-BO	6
33836-BO	2
33893-BO	6
33914-BO	1

Quantidades

CARTELA JUNTAS OM-364/366 - 33278-AN

BOMBA INJETORA N° ORIG.312.076.0279	TAMPA TRASEIRA DISTRIBUIÇÃO N° ORIG.343.015.0080 FIXAÇÃO REFRIGERADOR ÓLEO N° ORIG.312.188.1579	FLANGE BOMBA ALIMENTADORA N° ORIG.000.091.0580 CAMISA COMPRESSOR N° ORIG.321.131.0079
---	--	--

CARTELA JUNTAS OM-364/366 33279-AN

TAMPA DISTRIBUIÇÃO N° ORIG.352.015.0320	CARCAÇA BOMBA D'ÁGUA N° ORIG.352.201.0480 CAVALETE D'ÁGUA N° ORIG.352.203.0680	TERMOSTATO N° ORIG.366.203.0080 TUBO ENCHIMENTO ÓLEO N° ORIG.346.018.0080
---	---	--

KIT ARRUELAS MB 352/352A/366 33831-CU

	8,2 X 13,9 X 1,0mm	8,3 X 11,9 X 1,0mm	10,2 X 14,0 X 1,0mm	26,4 X 31,8 X 2,0mm
ARRUELA DUPLA RETORNO ÓLEO N° ORIG.3520780080	 24,3 X 28,6 X 2,0mm	 24,4 X 31,6mm	 9,6 X 20,6 X 1,0mm	 22,2 X 27,8 X 1,5mm
	14,6 X 17,9 X 1,5mm	14,2 X 19,9 X 1,5mm	16,4 X 21,9 X 1,5mm	18,2 X 21,9 X 1,5mm
	 14,6 X 17,9 X 1,5mm	 14,2 X 19,9 X 1,5mm	 16,4 X 21,9 X 1,5mm	 18,2 X 21,9 X 1,5mm

KIT DE BORRACHAS KB-33939

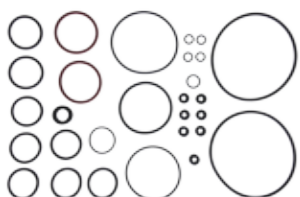

VEDADOR 12,4 x 2,6 33819-BO	VEDADOR 6,0 x 14,0 x 7,5 33226-BO	ARRUELA 14,2 x 19,9 x 1,5mm 33761-AL	VEDADOR REFRIGER. ÓLEO 64 x 2,5 33893-BO N° ORIG.2.413.682
---	---	--	---

CABEÇOTE OM 366 / 366A (100mm INOX)

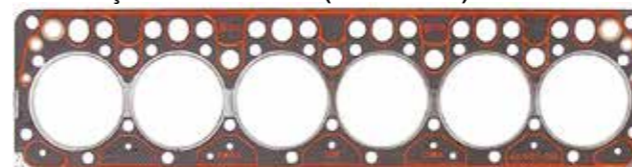

33281-OR
N° ORIG.366.016.0020

TAMPA DE VÁLVULA OM 366

33105-SC
N° ORIG.366.016.0021

VEDADOR TAMPA LATERAL VÁLVULA OM 366

33285-BO
N° ORIG.352.015.0160

TAMPA RADIADOR

33010-PP
N° ORIG.312.188.14.79

VEDAÇÃO

33286-PP

FILTRO ÓLEO OM 314



33224-AN
N° ORIG.314.184.0379

CABEÇOTE COMPRESSOR OM 314/352/ A /355



33017-SC
N° ORIG.352.131.0380

BOMBA D'ÁGUA OM -366 (C/AÇO INOX)



33291-AI-AN
N° ORIG.362.201.0080

COLETOR ADMISSÃO OM 364 / 366



33244-SC
N° ORIG.366.141.0380

SAÍDA ESCAPAMENTO OM 355 / 366



33106-FF
N° ORIG.600.492.0080

VEDADOR 60,5 x 3
33914-BO

RETENTOR DIANT.

1174V

VEDADOR 60 x 4,2
33826-BO

VEDADOR 75,0x 3,0mm
33827-BO

FILTRO RADIADOR ÓLEO OM-366

33103-AN

RETORNO ÓLEO MWM TD229 4/6 Cil. OM 366LA

33721-AN

TAMPA DISTRIBUIÇÃO (LA)



33248-AN

VEDADOR 115,0 x 125,0 x 5,0mm



33836-BO

COLETOR ADMISSÃO TURBINA OM- 366



33284-AN
N° ORIG.321.131.0079

BAINHA VARELA ÓLEO OM -366



33107-AN
N° ORIG.352.018.0980

VEDADOR 34,0x 4,0mm



33828-BO

VEDADOR 8,0 x 2,5



33821-BO

VEDADOR 13,5 x 23,0 x 7,0



33820-BO

VEDADOR 45 x 4



33829-SI

ANEL BORRACHA



33835-BO

VEDADOR 30,8 x 3,7



33833-BO
N° ORIG.346.997.0445

JOGO CARTER L 321/OM 352/366 6Cils.



LATERAL DIREITA CARTER CURVA 33002-CL
EXTREMIDADE DIANT/TRAS. 33282-BO
LATERAL ESQUERDA CARTER RETA 33001-CL

TAMPA INSPEÇÃO DISTRIBUIÇÃO OM 352/352A

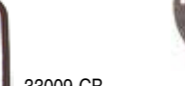

33009-CB
N° ORIG.312.015.0680

BASE TURBINA (COBRE) OM 352A/F-1000/D-20



33232-CI
N° ORIG.352.098.0280

LATERAL TURBINA OM 352A/F-1000/D-20



33228-CV
N° ORIG.352.098.0880

BASE COMPRESSOR



33288-AN

REFRIGERAÇÃO ÓLEO CAB. OM 366/447/449



33271-AN
N° ORIG.917.003.026000

GAXETA



33832-A
N° ORIG.000.997.9641

RETENTORA ÓLEO CARTER - OM 352A



33230-AN

COLETOR ESCAPAMENTO OM 364/366

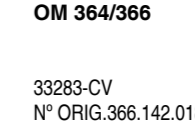

33283-CV
N° ORIG.366.142.0180

ENTRADA ÓLEO TURBINA OM352 A



33233-AN

MERCEDES-BENZ
OM 355-5

N° CORTECO	DESCRIÇÃO DO JOGO
48909ECO	MERCEDES OM 355 5 CILS. COM CABEÇOTE "TD" / COM RETENTORES

Componentes do Jogo

33214-SC	1
33282-BO	2
33106-FF	1
33110-CL	1
33013-CB	1
33296-TD	1
33297-TD	1
33298-AN	1
33299-AN	1
33300-SC	1
33301-AC	5
33302-SC	1
33303-SC	5
33304-AN	1
33307-SC	1
33308-AN	1
33837-OR	1
33309-AN	1
33310-BO	1
33312-BO	5
KB-33937	1
33293-AN	1
33294-AN	1
33295-AN	1
1200N	1
1218V	1
9111N	1
3110V	20

Quantidades

CARTELA DE JUNTAS OM355 - 33294-AN

CARCAÇA BOMBA INJETORA N° ORIG.327.075.0180	TUBO VENTILAÇÃO N° ORIG.07151 040017	TUBULAÇÃO D'ÁGUA N° ORIG.326.997.0149	TUBULAÇÃO D'ÁGUA N° ORIG.355.201.0080
COMPRESSOR DE AR N° ORIG.000.131.2079	CARCAÇA TERMOSTATO N° ORIG.355.203.0080	COMPRESSOR DE AR N° ORIG.000.131.2179	CARCAÇA BOMBA D'ÁGUA N° ORIG.356.201.0180
	TUBO ENCHIMENTO ÓLEO N° ORIG.346.018.0080		

COLETOR ADMISSÃO



CARTELA DE JUNTAS 33295-AN

BAINHA VARETA ÓLEO N° ORIG.303.018.0079	CARCAÇA BOMBA ÓLEO N° ORIG.065.181.0079	FLANGE BOMBA ALIMENTADORA N° ORIG.000.091.1280	SUORTE BOMBA D'ÁGUA N° ORIG.315.201.0180
--	--	---	---

RETENTOR DISTRIBUIÇÃO



RETENTOR ACOPLAMENTO BOMBA INJETORA



SAÍDA ESCAPAMENTO OM 355 / 366



VEDADOR TUBULAÇÃO ARREFECIMENTO



JOGO ARRUELAS OM 355 5/6 Cils. 33837-OR

18,2 x 21,9 x 1,5mm	14,0 x 17,5 x 1,5mm	14,3 x 17,7mm	ARRUELA DUPLA RETORNO ÓLEO N° ORIG.352.078.0080
10,2 x 14,0 x 1,0mm	24,3 x 28,6 x 2,0mm	22,2 x 26,9 x 1,5mm	30,2 x 36,0 x 2,0mm
8,2 x 13,9 x 1,0mm	8,3 x 11,9 x 1,0mm	9,6 x 20,6 x 1,0mm	35,3 x 40,8 x 2,0mm

RETENTOR HASTE VÁLVULAS



RETENTOR GUARDA PÓ VOLANTE



BOCAL EMCHIMENTO ÓLEO



CABEÇOTE OM 355 3 CIL (INOX)



CABEÇOTE OM 355 2 CIL (INOX)



TAMPA LATERAL VÁLVULA MENOR - OM 355 CIL



JUNTA TAMPA DO CILINDRO OM 355 5 CILS.



TAMPA LATERAL VÁLVULA MAIOR OM 355 5/6

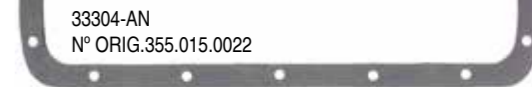

CABEÇOTE COMPRESSOR



JUNTA COMPRESSOR



COLETOR ADMISSÃO OM 355 5Cil.



COLETOR ADMISSÃO OM 355 5/6 Cil.



TAMPA DISTRIBUIÇÃO OM 326/355 5/6 Cil.

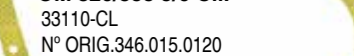

JOGO CARTER OM 355 5Cils. - 33023-AN
N° ORIG.345.586.7001

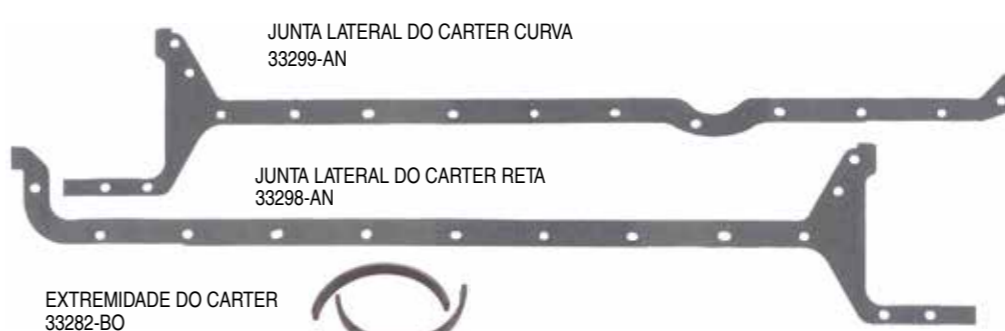

TAMPA DE VÁLVULAS OM 355 5/6 Cils.



SUORTE BOMBA INJETORA
N° ORIG.346.007.0380



CARTELA DE JUNTAS OM 355 33293-AN

CORPO FILTRO REFRIGERAÇÃO ÓLEO N° ORIG.315.184.0180	TUBO BOMBA D'ÁGUA N° ORIG.326.203.0083	CARCAÇA REFRIGERADOR ÓLEO N° ORIG.355.188.0080
SUORTE FILTRO ÓLEO N° ORIG.355.184.0480	TUBULAÇÃO D'ÁGUA N° ORIG. 326.997.0149	TAMPA CARCAÇA BOMBA ÓLEO N° ORIG.071511 026003
		TUBULAÇÃO D'ÁGUA N° ORIG. 355.201.0080

COLETOR ESCAPAMENTO OM 355 5/6 Cils.



MERCEDES-BENZ
OM 355-6

N° CORTECO	DESCRIÇÃO DO JOGO
48908ECO	MERCEDES OM 355 6 CILS. C/ CABEÇOTE "TD" C/RETENORES

Componentes do Jogo

- SK-33938
- 33214-SC
- 33282-BO
- 33106-FF
- 33108-AN
- 33109-AN
- 33110-CL
- 33013-CB
- 33296-TD
- 33301-AC
- 33302-SC
- 33303-SC
- 33304-AN
- 33305-AN
- 33293-AN
- 33294-AN
- 33295-AN
- 33307-SC
- 33837-OR
- 33310-BO
- 33312-BO
- 1218V
- 9111N
- 3110V
- 1200N

- Quantidades
- 1
 - 1
 - 2
 - 1
 - 1
 - 1
 - 1
 - 1
 - 1
 - 2
 - 6
 - 2
 - 6
 - 2
 - 1
 - 1
 - 1
 - 1
 - 1
 - 1
 - 1
 - 6
 - 1
 - 1
 - 1
 - 24
 - 1

CARTELA DE JUNTAS OM355 - 33294-AN

CARCAÇA BOMBA INJETORA N° ORIG.327.075.0180	TUBO VENTILAÇÃO N° ORIG.07151 040017	TUBULAÇÃO D'ÁGUA N° ORIG.326.997.0149	TUBULAÇÃO D'ÁGUA N° ORIG.355.201.0080
COMPRESSOR DE AR N° ORIG.000.131.2079	CARCAÇA TERMOSTATO N° ORIG.355.203.0080	COMPRESSOR DE AR N° ORIG.000.131.2179	CARCAÇA BOMBA D'ÁGUA N° ORIG.356.201.0180
	TUBO ENCHIMENTO ÓLEO N° ORIG.346.018.0080		

RETENTOR ACOPL. BOMBA INJETORA



RETENTOR GUARDA PÓ VOLANTE



TUBULAÇÃO D'ÁGUA



SAÍDA ESCAPAMENTO OM 355 / 366



CARTELA DE JUNTAS - 33295-AN

BAINHA VARETA ÓLEO N° ORIG.303.018.0079	CARCAÇA BOMBA ÓLEO N° ORIG.065.181.0079	FLANGE BOMBA ALIMENTADORA N° ORIG.000.091.1280	SUPORTE BOMBA D'ÁGUA N° ORIG.315.201.0180
--	--	---	--

JOGO ARRUELAS OM 355 5/6 Cils. 33837-OR

18,2 x 21,9 x 1,5mm	14,0 x 17,5 x 1,5mm	14,3 x 17,7mm	ARRUELA DUPLA RETORNO ÓLEO N° ORIG.352.078.0080
10,2 x 14,0 x 1,0mm	24,3 x 28,6 x 2,0mm	22,2 x 26,9 x 1,5mm	30,2 x 36,0 x 2,0mm
8,2 x 13,9 x 1,0mm	8,3 x 11,9 x 1,0mm	9,6 x 20,6 x 1,0mm	35,3 x 40,8 x 2,0mm

CABEÇOTE OM 355 3 CIL (INOX)



JUNTA COMPRESSOR



CABEÇOTE COMPRESSOR



COLETOR ADMISSÃO



VEDADOR TUBULAÇÃO ARREFECIMENTO



RETENTOR HASTE VÁLVULAS



RETENTOR DISTRIBUIÇÃO



COLETOR ADMISSÃO OM 355 5/6Cils.



TAMPA DE VÁLVULAS OM 355 5/6 Cils.



JOGO CARTER OM 355/326/346 6Cils. N° ORIG.355.586.0001 33024-AN



COLETOR ESCAPAMENTO (AÇO) OM 355 5/6 Cils.



BOCAL ENCHIMENTO ÓLEO



CARTELA DE JUNTAS OM 355 33293-AN

SUPORTE FILTRO ÓLEO N° ORIG.355.184.0480	CORPO FILTRO REFRIGERAÇÃO ÓLEO N° ORIG.315.184.0180	TUBO BOMBA D'ÁGUA N° ORIG.326.203.0083	CARCAÇA REFRIGERADOR ÓLEO N° ORIG.355.188.0080
TUBULAÇÃO D'ÁGUA N° ORIG. 326.997.0149	TAMPA CARCAÇA BOMBA ÓLEO N° ORIG.071511 026003	TUBULAÇÃO D'ÁGUA N° ORIG. 355.201.0080	

MERCEDES-BENZ
OM 447/449

N° CORTECO

DESCRIÇÃO DO JOGO

80281ECO	MERCEDES OM 447 6 CILS. C/ RETENORES HASTE VÁLVULAS
80326ECO	RETIFICA VÁLVULAS P/1 CABEÇOTE OM 447/449 C/RETENORES HASTE VÁLVULAS
80282ECO	MERCEDES OM 449 5 CILS.C/ RETENORES HASTE VÁLVULAS

Componentes do Jogo

33231-AN	1	1
33235-BI	6	1 5
33239-AN		1
33240-AN	1	
33243-AC	6	1 5
33245-SC	6	1 5
33247-SC	6	1 5
33250-AN	1	1
33251-SC	1	1
33822-BO	12	2 10
33252-AN	1	1
33254-AN	1	1
33255-AN	1	1
33256-AN	1	1
33257-AN	1	1
33259-AN	1	1
33262-CB	1	1
33263-AN	1	1
33824-BO	6	6
33270-AN	1	1
33271-AN	2	2
33274-AN	1	1
33275-AN	1	1
33276-AN	1	1
33106-FF	1	1
1381V	1	1
1387V	1	1
3252V	12	2 10
33758-CU		1
KA-33793	1	1
KB-33947	1	
KB-33948		1

Quantidades

RETENOR HASTE VÁLVULAS



JUNTA



RETENOR TRASEIRO



SAÍDA ESCAPAMENTO OM 355/366/447/449



RETENOR DIANTEIRO



KIT BORRACHAS OM 447 6Cils.- KB-33947



KIT BORRACHAS OM 449 5Cils. - KB-33948

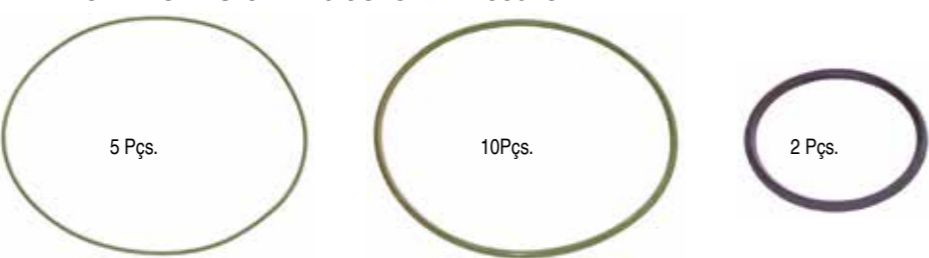

KIT ARRUELAS OM 447 / 449 KA-33793

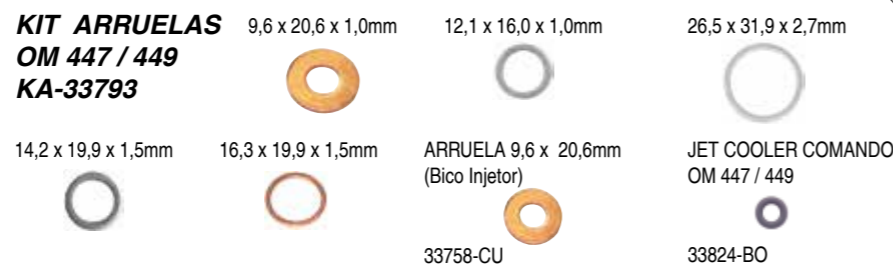

COLETOR ADMISSÃO OM 447 / 449



FLANGE CONEXÃO AQUECEDOR OM 447 / 449



CABEÇOTE OM 447/449 C/ ANEIS INJETADOS



CARTER OM 449 5Cils. N° ORIG.405.014.0222- 33239-AN



CARTER OM 447 6Cils. N° ORIG.407.014.0222 - 33240-AN



TAMPA DE VÁLVULAS OM 447/449



TUBO COLETOR ADMISSÃO AR OM 447/449



PENEIRA BOMBA ÓLEO OM 447 / 449



TUBO COLETOR ADMISSÃO ENTRADA AR OM 447/449



BOMBA D'ÁGUA OM 447/449



JUNTA TURBINA



REFRIGERAÇÃO ÓLEO CABEÇOTE OM 366/447/449



PLUG DO BICO INJETOR OM 447 / 449



CONEXÃO BOMBA D'ÁGUA OM 447 / 449



ENTRADA ÓLEO OM 447 / 449



SAÍDA ÓLEO OM 447 / 449



TAMPA ABASTECIMENTO ÓLEO CARTER OM 447/449



COLETOR ESCAPAMENTO OM 447 / 449



**MERCEDES-BENZ
OM 457 - ELETRÔNICO**

N° CORTECO

DESCRIÇÃO DO JOGO

80295ECO MERCEDES OM 457 6 CILS.C/ RETENORES HASTE VÁLVULAS
67790ECO RETIFICA VÁVULAS P/1 CABEÇOTE OM 457 6 CILS. C/RETENORES HASTE VÁLVULAS

**Componentes
do Jogo**

33236-BI	6	1
33238-AC	6	
33240-AN	1	
33243-AC	6	1
33246-SC	6	1
33251-SC	1	
33252-AN	1	
33231-AN	1	
33259-AN	1	
33260-NT	1	
33261-NT	1	
33823-VI	12	
33264-ML	1	
33265-SI	6	1
33266-NT	6	1
33271-AN	2	
33272-NT	1	
33273-NT	1	
1381V	1	
1387V	1	
7757V	24	4
33848-BO	1	
33405-BO	1	
33885-BO	1	
33894-BO	1	
11772-CU	1	1
KA-33804	1	

Quantidades

**BASE BOMBA ALIMENTADORA
AO BLOCO**



33264-ML
N° ORIG. 457.081.0180

**RETENTOR HASTE
VÁLVULAS OM 457**



7757V
N° ORIG.000.053.3558

VEDADOR



33848-BO
N° ORIG. 397.920

**ARRUELA 7,3 X 15,0MM
(BICO INJETOR)**



11772-CU

CONEXÃO PRE-AQUECIMENTO



33260-NT
N° ORIG. 460.201.0080

COLETOR ADMISSÃO



33246-SC
N° ORIG. 457.188.0280

**REFRIGERAÇÃO ÓLEO
CABEÇOTE**



33271-AN
N° ORIG.917.003.026000

RETENTOR DIANTEIRO



1381V
N° ORIG. 014.997.4647

**VEDADOR
BOMBA INJETORA**



33894-BO
N° ORIG. 2.415.813

**ENTRADA ÓLEO
OM 447 /449**



33259-AN
N° ORIG.617.187.0180

RETENTOR TRASEIRO



1387V
N° ORIG. 013.997.1447

VEDADOR



33885-BO

KIT ARRUELAS OM-457 6 Cil. - KA-33804



**CABEÇOTE OM 457 6 CILS.
C/ ANEIS INJETADOS**



33236-BI
N° ORIG.457.016.1120

**TAMPA DE VÁLVULAS OM 457
ELETRÔNICO (TAMPA PLASTICA)**



33265-SI
N° ORIG. 457.016.0221

**TAMPA DE VÁLVULAS OM 457
(TAMPA ALUMINIO)**



33266-NT
N° ORIG. 457.016.0021



**TAMPA DIANT. BLOCO
OM 457**
33272-NT
N° ORIG. 541.011.0080



**RADIADOR ÓLEO
OM 457 ELETRÔNICO**

33273-NT
N° ORIG.457.188.0280

CARTER OM 447/457 6Cils.



33240-AN
N° ORIG.405.014.0222

**COLETOR ESCAPAMENTO
OM 447/449/457**



33243-AC

JUNTA TURBINA



33231-AN

CONEXÃO BOMBA D'ÁGUA



33252-AN
N° ORIG. 422.201.0480

**VEDADOR
59 x 67 x 3,0**



33405-BO

**CALÇO DA CAMISA
OM 457**

33238-AC
N° ORIG. 457.011.0259
146 X145 MM



TAMPA DISTRIBUIÇÃO OM 447/449 /457

33251-SC
N° ORIG. 429.015.00.80

BOMBA D'ÁGUA OM 457



33261-NT
N° ORIG.457.201.0080

ANEL DA CAMISA OM 457

33823-VI
N° ORIG. 457.997.0545
144,5 X 154,1 X 7 MM

MERCEDES-BENZ
OM 457 2007/...
ELETRÔNICO

Componentes do Jogo

- 33238-AC
- 33241-AN
- 33242-AN
- 33237-BI
- 33251-SC
- 33252-AN
- 11772-CU
- 33231-AN
- 33259-AN
- 33260-NT
- 33261-NT
- 33823-VI
- 33264-ML
- 33265-SI
- 33267-AC
- 33268-BI
- 33269-BI
- 33271-AN
- 33272-NT
- 33277-SC
- KA-33804
- 8566T
- 3244T
- 7757V
- 33848-BO
- 33405-BO
- 33885-BO
- 33894-BO
- 33901-SC

- Quantidades
- 6
 - 1
 - 1
 - 1
 - 1
 - 1
 - 1
 - 1
 - 1
 - 1
 - 1
 - 12
 - 1
 - 6
 - 6
 - 6
 - 6
 - 2
 - 1
 - 1
 - 1
 - 1
 - 24
 - 1
 - 1
 - 1
 - 1
 - 1

N° CORTECO	DESCRIÇÃO DO JOGO
48404ECO	MERCEDES OM 457 2007/... 6 CILS.C/ RETENTORES
48405ECO	RETIFICA VÁLVULAS P/1 CABEÇOTE OM 457 2007/...6 CILS. C/RETENTORES HASTE VÁLVULAS

RETIFICA DE VÁLVULAS

JUNTA DE CABEÇOTE
33237-BI
N° ORIG.457.016.1220

TAMPA DE VÁLVULAS OM 457
Eletrônico (Tampa Plastica)
33265-SI
N° ORIG. 457.016.0221

COLETOR ESCAPAMENTO OM 457

ARRUELA 7,3 x 15,0mm
(Bico Injetor)
11772-CU

RETENTOR HASTE VÁLVULAS OM 457
7757V
N° ORIG.000.053.3558

COLETOR ADMISSÃO OM 457

JUNTA TURBINA
33268-BI
N° ORIG. A457.141.0080

JUNTA TURBINA
33269-BI
N° ORIG. A457.098.0180

CARTER OM 457 (CAMINHÕES)

33241-AN
N° ORIG. A457.014.0522

CARTER OM 457 (ONIBUS)

33242-AN
N° ORIG. A457.014.0222

RADIADOR ÓLEO OM 457 2007/..ELETRÔNICO
33277-SC
N° ORIG.457.188.0280

TAMPA DISTRIBUIÇÃO OM 447/449 /457
33251-SC
N° ORIG. 429.015.00.80

BASE BOMBA ALIMENTADORA AO BLOCO OM-457

33264-ML
N° ORIG. 457.081.0180

REFRIGERAÇÃO ÓLEO CABEÇOTE OM 366/447/449

33271-AN
N° ORIG.917.003.026000

ENTRADA ÓLEO OM 447 /449

33259-AN
N° ORIG.617.187.0180

CONEXÃO PRE-AQUECIMENTO OM 457

33260-NT
N° ORIG. 460.201.0080

RETENTOR HASTE VÁLVULAS OM 457

7757V
N° ORIG.000.053.3558

VEDADOR BOMBA INJETORA

33893-BO
N° ORIG. 2.415.813

RETENTOR DIANTEIRO

3244T
N° ORIG. 025.997.3947

RETENTOR TRASEIRO

8566T
N° ORIG. 025.997.5047

JUNTA DA TURBINA

33231-AN

CONEXÃO BOMBA D'ÁGUA OM 447 / 449

33252-AN
N° ORIG. 422.201.0480

VEDADOR 59 x 67 x 3,0

33405-BO

VEDADOR

33885-BO

VEDADOR

33848-BO
N° ORIG. 397.920

TAMPA DIANT. BLOCO OM 457

33272-NT
N° ORIG. 541.011.0080

BOMBA D'ÁGUA OM 457

33261-NT
N° ORIG.457.201.0080

CALÇO DA CAMISA OM 457 (0,15 mm)

33238-AC
N° ORIG. 457.011.0259
146 X155 MM

JUNTA DA FLANGE DO RETENTOR DIANTEIRO 2007/...

33901-SC

KIT ARRUELAS OM-457 6 Cil. - KA-33804

ANEL CAMISA OM 457

33823-VI
N° ORIG. 457.997.0545
144,5 X 154,1 X 7 MM

68 Seja original, seja Freudenberg-NOK

69

CORTECO
Divisão de Reposição

MERCEDES-BENZ
M 904 / 924
ELETRÔNICO

N° CORTECO	DESCRIÇÃO DO JOGO
47904ECO	MERCEDES OM 904 4 CILS. C/RETENTOR
47905ECO	RETIFICA VÁLVULAS 904 4 CILS. C/RETENTORES HASTE VÁLVULAS
48770ECO	MERCEDES OM 924 4 CILS. C/ RETENTORES
47924ECO	RETIFICA VÁLVULAS OM 924 4 CILS. C/RETENTORES HASTE VÁLVULAS
80904ECO	JOGO COMPLETO OM 904 COM JUNTA DE CABEÇOTE EM SC (FIBRA)

Componentes do Jogo

33192-BI	1	1		
33194-BI		1	1	
33198-CV	2	2	2	2
33199-ML	2	2	2	2
33200-ML	1	1	1	1
33201-BI	1	1	1	1
33202-NT	1	1	1	1
33203-NT	1	1	1	1
33205-SI	1	1	1	1
33206-SI	1	1	1	1
33209-NT	1	1	1	1
33814-KB	1	1	1	1
8566T	1	1	1	1
3243T	1	1	1	1
8425V	12	12	12	12
KA-33807	1	1	1	1
33811-BO	5	5	5	5
33812-BO	5	5	5	5
33193-SC				1

Quantidades

RETENTOR HASTE VÁLVULAS



8425V
N° ORIG. 906.053.0358

VEDADOR DO PRISIONEIRO DA TAMPA DE VÁLVULAS



33812-BO

COLETOR DE ADMISSÃO



33199-ML
N° ORIG.906.141.0180

DIANTEIRO VIRABREQUIM



3243T
N° ORIG. 022.997.7647

TRASEIRO VIRABREQUIM



8566T
N° ORIG. 021.997.5347

TUBO CIRCULAÇÃO D'ÁGUA DA CABEÇOTE (LATERAL)



33201-BI
N° ORIG. 906.203.0180

COLETOR DE ESCAPAMENTO



33198-CV
N° ORIG.906.142.0280

VEDADOR DO PRISIONEIRO DA TAMPA DE VÁLVULAS



33811-BO

KIT BORRACHAS - 33814-KB

CABEÇOTE OM 904/924 4CILS. C/ANÉIS INJETADOS



33192-BI (104 MM)
N° ORIG.904.016.1320

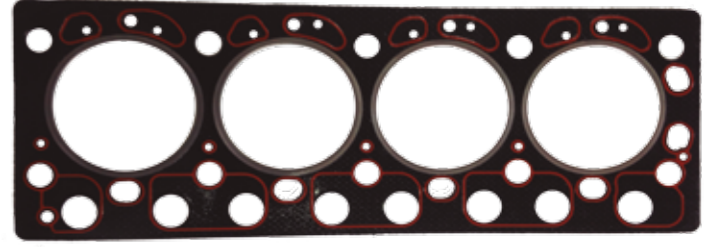

33194-BI (108 MM)
N° ORIG.924.016.1120

33193-TD (104 MM)
N° ORIG.906.016.1320



TAMPA DE VÁLVULAS OM 904 ELETRÔNICO (TAMPA ALUMÍNIO)
33205-SI
N° ORIG.904.016.0621



TAMPA DE VÁLVULAS OM 904 ELETRÔNICO (TAMPA PLÁSTICO)
33206-SI
N° ORIG.000.016.0421

KIT ARRUELAS OM -904/924 4 CILS. KA-33807



BASE BOMBA ALIMENTADORA



33200-ML
N° ORIG. 906.091.038



CARTER DE ÓLEO
33209-NT
N° ORIG.904.014.0622



BOMBA D'ÁGUA
33202-NT
N° ORIG. 906.201.0080



RADIADOR ÓLEO
33203-NT
N° ORIG.904.188.0280

MERCEDES-BENZ
OM 906 / 926
ELETRÔNICO

N° CORTECO	DESCRIÇÃO DO JOGO
80906ECO	MERCEDES OM 906 6 CILS. C/RETENTOR
79906ECO	RETIFICA VÁLVULAS 906 6 CILS. C/RETENORES HASTE VÁLVULAS
48780ECO	MERCEDES OM 926 6 CILS. C/ RETENORES
47926ECO	RETIFICA VÁLVULAS OM 926 6 CILS. C/RETENORES HASTE VÁLVULAS
47906ECO	MERCEDES OM 906 6 CILS. C/RETENTOR CABEÇOTE EM FIBRA

Componentes do Jogo

33195-BI	1	1		
33196-SC			1	
33197-BI		1	1	
33198-CV	3	3	3	3
33199-ML	3	3	3	3
33200-ML	1	1	1	1
33201-BI	1	1	1	1
33202-NT	1	1	1	1
33204-NT	1	1	1	1
33207-SI	1	1	1	1
33208-SI	1	1	1	1
33101-NT	1	1	1	1
33815-KB	1	1	1	1
8566T	1	1	1	1
3243T	1	1	1	1
8425V	18	18	18	18
KA-33808	1	1	1	1
33811-SI	7	7	7	7
33812-SI	7	7	7	7
33900-SC	1	1	1	1

Quantidades



COLETOR DE ADMISSÃO

33199-ML
N° ORIG.906.141.0180



BASE BOMBA ALIMENTADORA

33200-ML
N° ORIG. 906.091.038

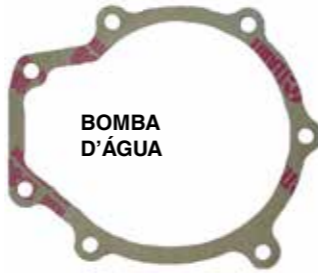

BOMBA D'ÁGUA

33202-NT
N° ORIG. 906.201.0080



DIANTEIRO VIRABREQUIM

3243T
N° ORIG. 022.997.7647



TRASEIRO VIRABREQUIM

8566T
N° ORIG. 021.997.5347



COLETOR DE ESCAPAMENTO

33198-CV
N° ORIG.906.142.0280

TUBO CIRCULAÇÃO D'ÁGUA DA CABEÇOTE (LATERAL)



33201-BI
N° ORIG. 906.203.0180

VEDADOR DO PRISIONEIRO DA TAMPA DE VÁLVULAS



33812-BO

RETENTOR HASTE VÁLVULAS



8425V
N° ORIG. 906.053.0358



RADIADOR ÓLEO

33204-NT
N° ORIG.906.188.0280

KIT ARRUELAS OM -906 / 926 6 CILS. KA-33808



KIT BORRACHA - 33815-KB

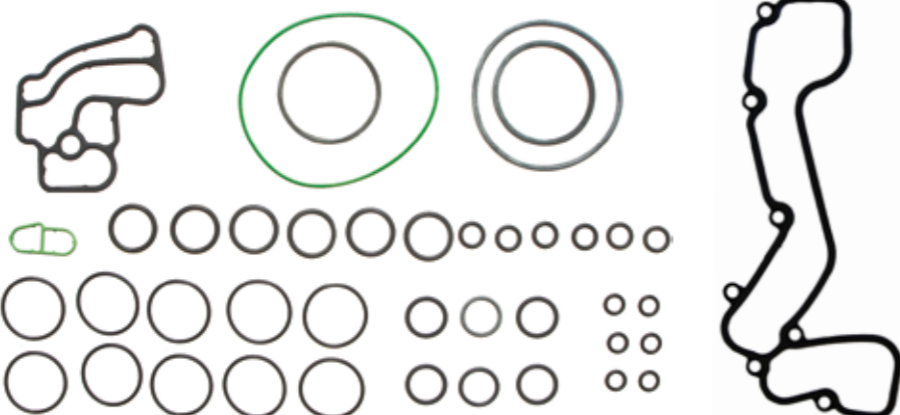

CABEÇOTE OM 906/926 6CILS. C/ANÉIS INJETADOS



33195-BI (104 MM) e 33197-BI
N° ORIG.906.016.1420

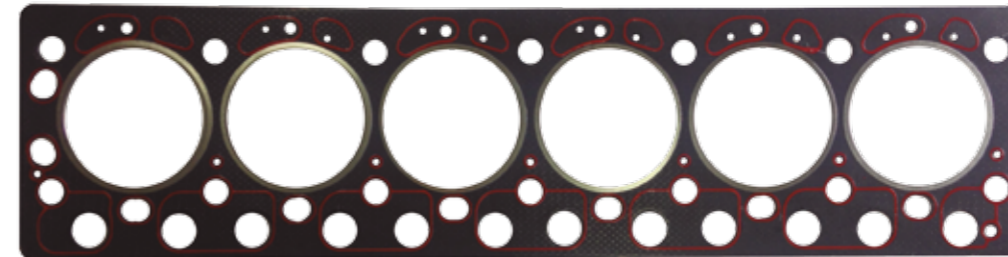

33196-SC (108 MM)
N° ORIG.926.016.1220



TAMPA DE VÁLVULAS OM 906/926 ELETRÔNICO (TAMPA ALUMÍNIO)
33207-SI
N° ORIG.906.016.0621



TAMPA DE VÁLVULAS OM 906/926 ELETRÔNICO (TAMPA PLÁSTICO)
33208-SI
N° ORIG.000.016.0521



CARTER DE ÓLEO

33101-NT
N° ORIG.906.014.0922

VEDADOR DO PRISIONEIRO DA TAMPA DE VÁLVULAS



33811-BO

JUNTA DA VÁLVULA DA SOLENOIDE - TOP BRAKE



33900-SC

N° CORTECO

DESCRIÇÃO DO JOGO

98950ECO

MERCEDES OM 611 ELETRÔNICO SPRINTER CDI 2000/... COMPLETO C/RETENTORES

Componentes do Jogo

8518T	1
7795T	1
3197V	16
33775-ML	1
33813-KB	1
33210-ML	1
33102-ML	1
33212-SI	1
33213-ML	1
KA-33799	1
33211-ML	1

Quantidades

RETENTOR TRASEIRO



8518T
N° ORIG. 611.010.0214

CABEÇOTE OM 611



33775-ML
N° ORIG. 611.016.0620

RETENTOR HASTE VÁLVULAS



3197V
N° ORIG. 000.053.4158

BOMBA D' ÁGUA



33102-ML
N° ORIG. 611.016.0620

TAMPA DE VÁLVULAS



33212-SI
N° ORIG. 611.016.0121

RETENTOR DIANTEIRO



7795T
N° ORIG. 021.997.7647

VÁLVULA EGR



33213-ML
N° ORIG. A611.203.0480



CARTER
33210-ML
N° ORIG. 642.014.0022

COLETOR DE ESCAPAMENTO



33211-ML

KIT ARRUELAS - KA-33799



KIT BORRACHAS - 33813-KB



ITENS AVULSOS

MERCEDES-BENZ

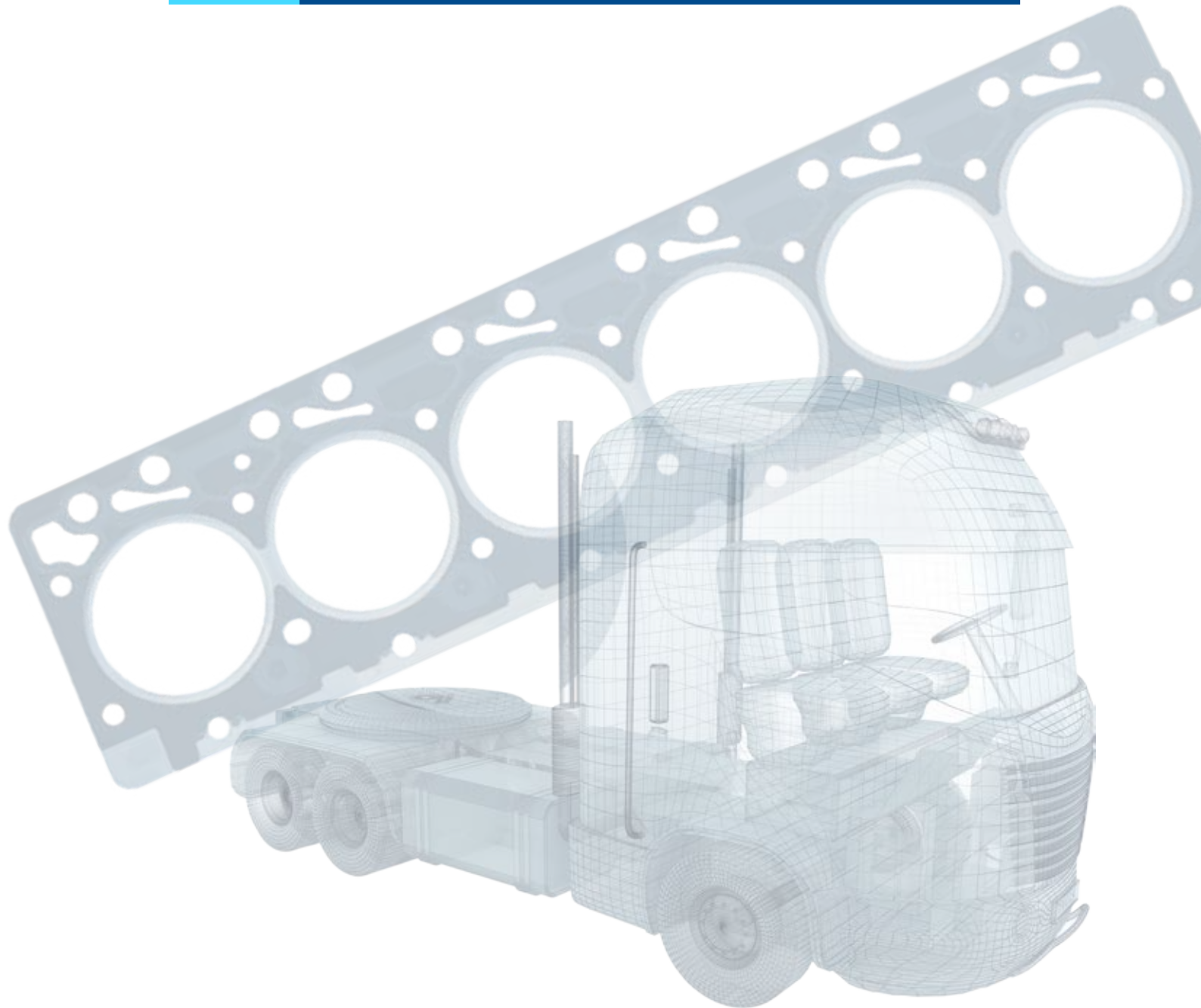

**MERCEDES-BENZ
AVULSOS**

Nº CORTECO

48306ECO

APLICAÇÃO

MERCEDES OM 314 4 CILINDROS.

**JOGO CARTER
48116ECO-CL**

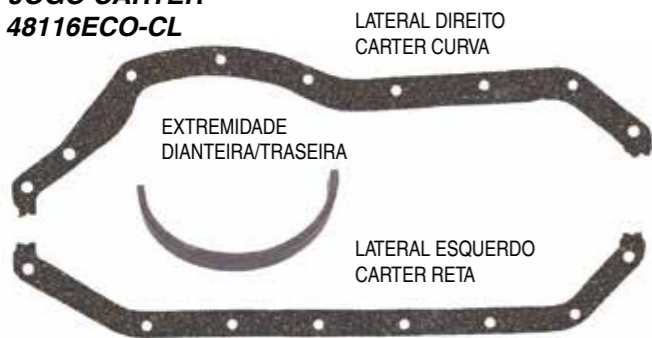

LATERAL DIREITO
CARTER CURVA

EXTREMIDADE
DIANTEIRA/TRASEIRA

LATERAL ESQUERDO
CARTER RETA

**TAMPA DE VÁLVULA - OM 324/TOYOTA
BANDEIRANTE**

48332ECO-SC
Nº ORIG. 314.016.0121

CABEÇOTE MBB 314/324/364 (INOX)

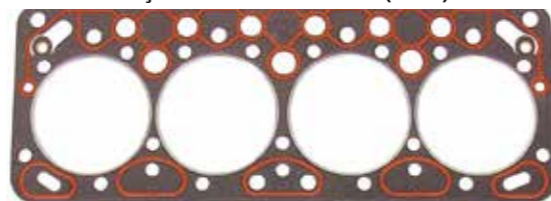

33250ECO-SC
Nº ORIG.314.016.0220

Nº CORTECO

48806ECO

48906ECO E 33180ECO

APLICAÇÃO

MERCEDES OM 352 6 CILINDROS.
MERCEDES OM 352A 6 CILINDROS.

CABEÇOTE OM 352/352A (100MM INOX)

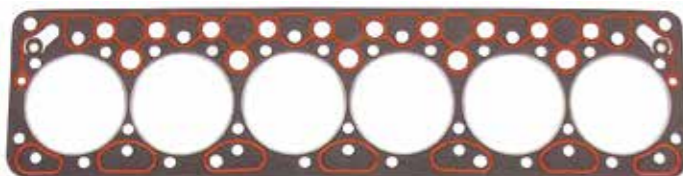

48802ECO-OR
Nº ORIG.352.016.1520

**TAMPA DE VÁLVULA OM
352/352A**

48832ECO-SC
Nº ORIG.352.016.0421

JOGO CARTER L 321/OM 352/366 6Cils. - 48816ECO-CL

LATERAL DIREITA CARTER CURVA



EXTREMIDADE
DIANT/TRAS.

LATERAL ESQUERDA CARTER RETA

**TAMPA LATERAL VÁLVULAS
OM 352/352A/321**

48527ECO-CB
Nº ORIG.352.015.0122

Nº CORTECO

21740ECO

APLICAÇÃO

MERCEDES OM 364 4 CILS. TURBINADO

CABEÇOTE MBB OM 364

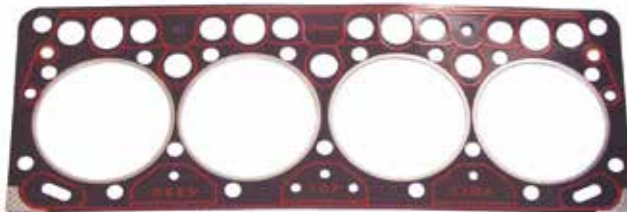

48301ECO-SC
Nº ORIG. 364.016.0320

TAMPA DE VÁLVULAS OM-364 4CILS.

48318ECO-SC
Nº ORIG.364.016.0021

Nº CORTECO

48606ECO

80270ECO

APLICAÇÃO

MERCEDES OM 366 ASPIRADO

MERCEDES OM 366A/LA TURBINADO ASPIRADO

CABEÇOTE OM 366 / 366A (100MM INOX)

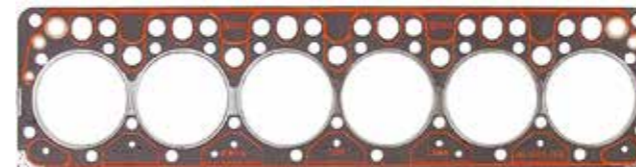

82175ECO-OR
Nº ORIG.366.016.0020

TAMPA DE VÁLVULA OM 366

48626ECO-SC
Nº ORIG.366.016.0021

VEDADOR TAMPA LATERAL VÁLVULA OM 366

48627ECO-BO
Nº ORIG.352.015.0160

Nº CORTECO

48908ECO

APLICAÇÃO

MERCEDES OM 355 6 CILINDROS.

**JOGO CARTER OM 355/326/346
6Cils.
Nº ORIG.355.586.0001
48716ECO-AN**

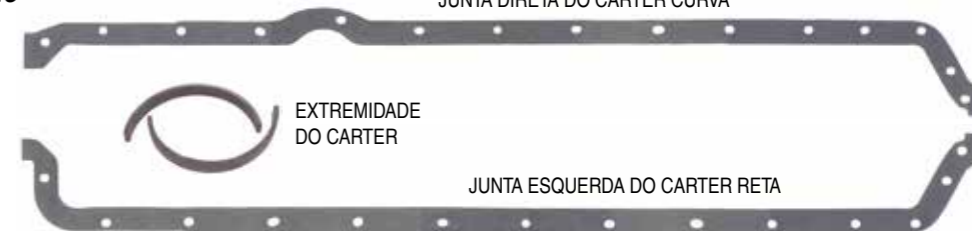

JUNTA DIRETA DO CARTER CURVA

EXTREMIDADE
DO CARTER

JUNTA ESQUERDA DO CARTER RETA

CABEÇOTE OM 355 3 CIL (INOX)



48901ECO-TD
Nº ORIG.355.016.0220

**TAMPA DE VÁLVULAS
OM 355 5/6 CILS.**

48926ECO-SC
ORIG.346.016.0221

Nº CORTECO

48909ECO

APLICAÇÃO

MERCEDES OM 355 5 CILS. COM CABEÇOTE "TD"

CABEÇOTE OM 355 3 CIL (INOX)



48901ECO-TD
Nº ORIG.355.016.0220

CABEÇOTE OM 355 2 CIL (INOX)



48902ECO-TD
Nº ORIG.355.016.0220

**TAMPA DE VÁLVULAS
OM 355 5/6 CILS.**

48926ECO-SC
ORIG.346.016.0221

**Nº ORIG.345.586.7001- JOGO CARTER OM 355 5Cils.
48917ECO-AN**

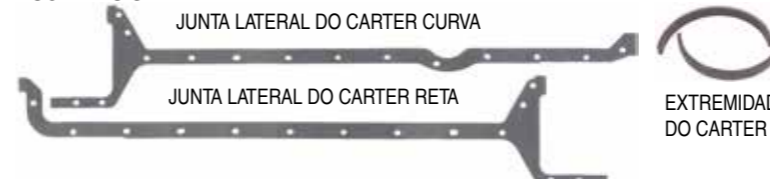

JUNTA LATERAL DO CARTER CURVA

JUNTA LATERAL DO CARTER RETA

EXTREMIDADE
DO CARTER

**MERCEDES-BENZ
AVULSOS**

N° CORTECO	APLICAÇÃO
80282ECO	MERCEDES OM 449 5 CILINDROS.

CABEÇOTE OM 447/449 C/ ANEIS INJETADOS



99971ECO-BI
N° ORIG.422.016.0420

**CARTER OM 449 5Cils.- N° ORIG.405.014.0222
48416ECO-AN**

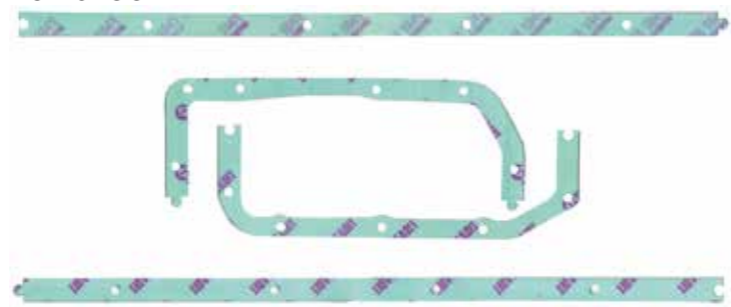

N° CORTECO	APLICAÇÃO
80326ECO	MERCEDES OM 447/449.

TAMPA DE VÁLVULAS OM 447/449



96120ECO-SC
N° ORIG. 403.016.03.21

CABEÇOTE OM 447/449 C/ ANEIS INJETADOS



99971ECO-BI
N° ORIG.422.016.0420

N° CORTECO	APLICAÇÃO
80295ECO E 67790ECO	MERCEDES OM 457 6 CILINDROS.

CABEÇOTE OM 457 6 CILS. C/ ANEIS INJETADOS



82295ECO-BI
N° ORIG.457.016.1120

TAMPA DE VÁLVULAS OM 457 ELETRÔNICO (TAMPA PLÁSTICA)



01796ECO-SI
N° ORIG. 457.016.0221

TAMPA DE VÁLVULAS OM 457 (TAMPA ALUMÍNIO)



96297ECO-NT
N° ORIG. 457.016.0021

**CARTER OM 447/457 6Cils. - N° ORIG.405.014.0222
96295ECO-AN**



N° CORTECO	APLICAÇÃO
80904ECO, 47904ECO E 47905ECO	MERCEDES OM 904 4 CILINDROS.

CABEÇOTE OM 904/924 4CILS. C/ANEIS INJETADOS



99914ECO-BI (104MM)
N° ORIG.904.016.1320

TAMPA DE VÁLVULAS OM 447/449



96120ECO-SC
N° ORIG. 403.016.03.21



TAMPA DE VÁLVULAS OM 904 ELETRÔNICO (TAMPA ALUMÍNIO)

45561ECO-SI
N° ORIG.904.016.0621



TAMPA DE VÁLVULAS OM 904 ELETRÔNICO (TAMPA PLÁSTICO)

74800ECO-SI
N° ORIG.000.016.0421



CARTER DE ÓLEO

95904ECO-NT
N° ORIG.904.014.0622

**MERCEDES-BENZ
AVULSOS**

N° CORTECO

48770ECO E 47924ECO

APLICAÇÃO

MERCEDES OM 924 4 CILINDROS

**CABEÇOTE OM 904/924 4CILS.
C/ANEIS INJETADOS**



53512ECO-BI (104 MM)
N° ORIG.924.016.1120

CARTER DE ÓLEO

95904ECO-NT
N° ORIG.904.014.0622



**TAMPA DE VÁLVULAS OM 904
ELETRÔNICO (TAMPA ALUMÍNIO)**

45561ECO-SI
N° ORIG.904.016.0621



**TAMPA DE VÁLVULAS OM 904
ELETRÔNICO (TAMPA PLÁSTICO)**

74800ECO-SI
N° ORIG.000.016.0421



N° CORTECO

98950ECO

APLICAÇÃO

MERCEDES OM 611 ELETRÔNICO SPRINTER CDI 2000/...

CABEÇOTE OM 611



82297ECO-ML
N° ORIG. 611.016.0620

CARTER

99297ECO-ML
N° ORIG. 642.014.0022



TAMPA DE VÁLVULAS

75295ECO-SI
N° ORIG. 611.016.0121

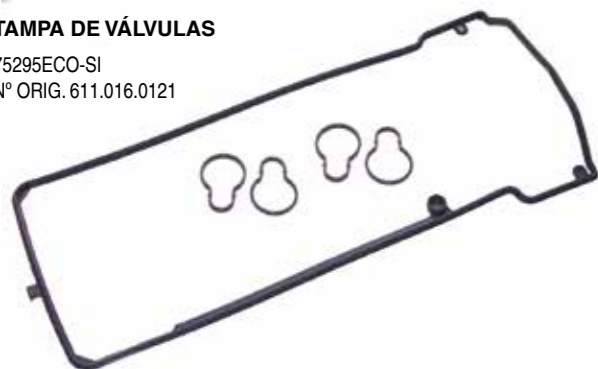

N° CORTECO

48404ECO E 48405ECO

APLICAÇÃO

MERCEDES OM 457 2007/... 6 CILINDROS.

JUNTA DE CABEÇOTE



80294ECO-BI
N° ORIG.457.016.1220

**CABEÇOTE OM 447/449 C/ ANEIS
INJETADOS**



99971ECO-BI
N° ORIG.422.016.0420

**TAMPA DE VÁLVULAS OM 457
ELETRÔNICO (TAMPA PLASTICA)**

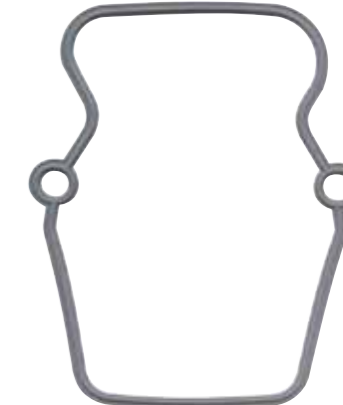

01796ECO-SI
N° ORIG. 457.016.0221

CARTER OM 457 (ÔNIBUS)

48419ECO-AN
N° ORIG. A457.014.0222

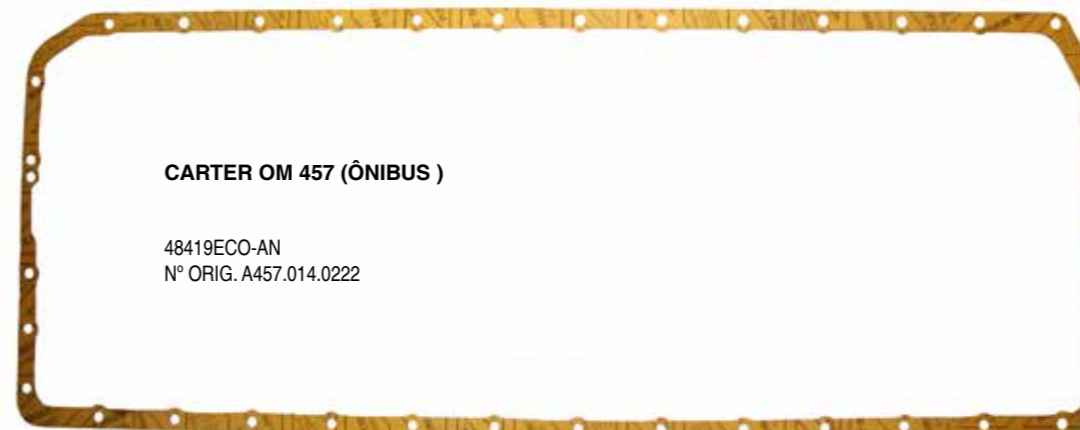

CARTER OM 457 (CAMINHÕES)

48418ECO-AN
N° ORIG.
A457.014.0522



**MERCEDES-BENZ
AVULSOS**

N° CORTECO

80906ECO, 47906ECO E 79906ECO

APLICAÇÃO

MERCEDES OM 906 6 CILINDROS.

**TAMPA DE VÁLVULAS OM 906/926
ELETRÔNICO (TAMPA ALUMÍNIO)**

50320ECO-SI
N° ORIG.906.016.0621



**TAMPA DE VÁLVULAS OM 906/926
ELETRÔNICO (TAMPA PLÁSTICO)**

74790ECO-SI
N° ORIG.000.016.0521



**CABEÇOTE OM 906/926 6CILS.
C/ANÉIS INJETADOS**



99916ECO-BI (104 MM)
N° ORIG.906.016.1420

CARTER DE ÓLEO

95906ECO-NT
N° ORIG.906.014.0922



N° CORTECO

47926ECO E 48780ECO

APLICAÇÃO

MERCEDES OM 926 6 CILINDROS

**TAMPA DE VÁLVULAS OM 906/926
ELETRÔNICO (TAMPA ALUMÍNIO)**

50320ECO-SI
N° ORIG.906.016.0621



**TAMPA DE VÁLVULAS OM 906/926
ELETRÔNICO (TAMPA PLÁSTICO)**

74790ECO-SI
N° ORIG.000.016.0521



**CABEÇOTE OM 906/926 6CILS.
C/ANÉIS INJETADOS**



47004ECO-BI (108 MM)
N° ORIG.926.016.1220

CARTER DE ÓLEO

95906ECO-NT
N° ORIG.906.014.0922



N° CORTECO

80364ECO

APLICAÇÃO

MERCEDES OM 364 4 CILINDROS.

CABEÇOTE MBB 314/324/364 (INOX)

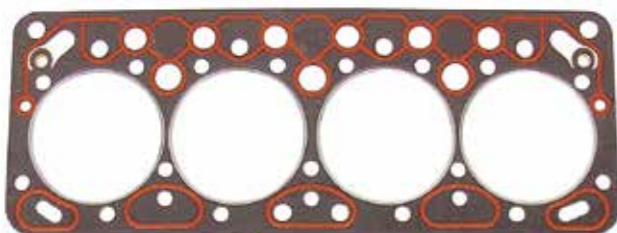

33250ECO-SC
N° ORIG.314.016.0220

TAMPA DE VÁLVULAS OM-364 4CILS.

48318ECO-SC
N° ORIG.364.016.0021



N° CORTECO

80281ECO

APLICAÇÃO

MERCEDES OM 447 6 CILINDROS.

**CABEÇOTE OM 447/449
C/ ANÉIS INJETADOS**



99971ECO-BI
N° ORIG.422.016.0420

**CARTER OM 447/457 6CILs. - N° ORIG.405.014.0222
96295ECO-AN**

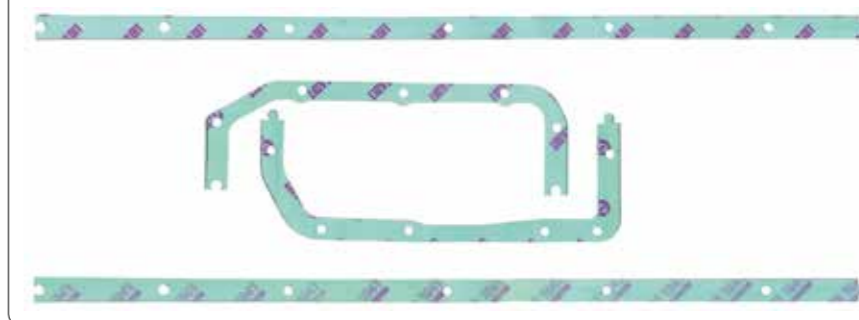

APLICAÇÃO

MOTOR OM352A / 366 / 366A / 366LA



KITS DE JUNTAS **MWM**

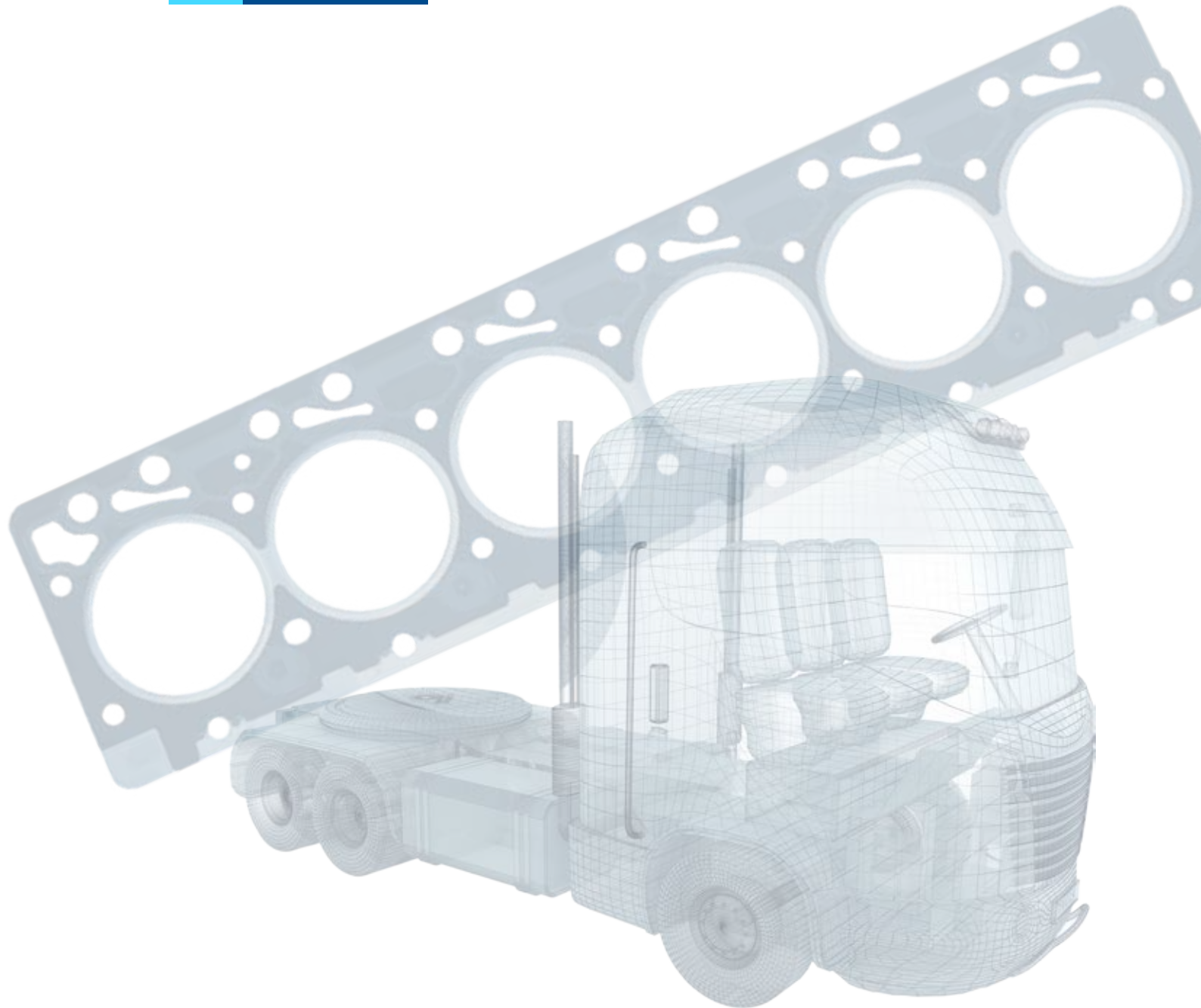







MWM
D-229-4 SÉRIE TD

N° CORTECO	DESCRIÇÃO DO JOGO
71112ECO	MWM D 229 4 CILS. VEICULAR F 1000 /2000 VW 6.90/7.90. C/CABEÇOTE TD C/RETENORES VI

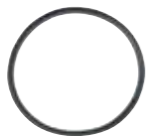
Componentes do Jogo

- 44663-AN 1
- 44665-TD 4
- 44897-BO 4
- 44671-BO 1
- 44899-BO 1
- 44678-AN 1
- 44900-A 1
- 44902-BO 1
- 44903-BO 1
- 44904-BO 1
- 44905-BO 1
- 44699-AN 1
- 44700-AN 1
- 44703-SC 8
- 44704-FF 1
- 44705-SC 2
- 44706-NT 1
- 44910-SI 8
- 124V 1
- 121V 1
- KA-44791 1

Quantidades







<p>VEDADOR 42 x 3 ORIG. 6.0493.10.4.0423</p>  <p>44905-BO</p>	<p>ANEL 029.010.332.00-59 66 x 5.33-2332</p>  <p>44899-BO</p>	<p>VEDAÇÃO CAMISA MWM D229/TD229 44910-SI N° ORIG.6.0493.13.0.1124</p> 	
<p>VEDADOR O'RING 20 x 4</p>  <p>44902-BO</p>	<p>VEDADOR O'RING 32 x 4</p>  <p>44903-BO</p>	<p>VEDADOR 6 x 2 N° ORIG. 6.0493.10.4.0062</p>  <p>44904-BO</p>	<p>VEDADOR BOMBA ALIMENTADORA</p>  <p>44671-BO</p>

KIT ARRUELAS MWM D-229/4
KIT COM 38 ARRUELAS
KA-44791



1 Pç. 1 Pç. 2 Pçs. 1 Pç. 2 Pçs. 2 Pçs. 8 Pçs. 4 Pçs. 4 Pçs.

CARTELA MWM 225 / 226 / 229 - 44663-AN

<p>BOMBA ALIMENTADORA</p>  <p>N° ORIG.6.321.4.853.012.4</p>	<p>TAMPA TRASEIRA N° ORIG.6.325.0.853.005.4</p> 	<p>SUORTE BOMBA D'ÁGUA</p>  <p>N° ORIG.6.321.0.853.001.4</p>
<p>TAMPA INSPEÇÃO</p>  <p>N° ORIG.6.325.0.853.015.4</p>	<p>FILTRO LUBRIFICANTE</p>  <p>N° ORIG.9.305.0.853.021.4</p>	<p>BOMBA INJETORA</p>  <p>N° ORIG.6.205.0.853.012.4</p>

CABEÇOTE MWM D229/TD229



44665-TD



CARTER MWM 225/226/229 4Cils.
44706-NT
N° ORIG.9.229.0.853.040.6



TAMPA FRONTAL MWM D225/226/229
44699-AN
N° ORIG.6.325.0.853.018.4

BOMBA D'ÁGUA MWM D222/225/226/229



44700-AN
N° ORIG.9.222.0.853.013.4

COTOVELO ESCAPAMENTO MWM D225/226/229



44705-SC
N° ORIG. 9.225.0.851.001.4

ANEL 20 x 2



44897-BO

FILTRO DE AR



44678-AN

TAMPA DE VÁLVULA MWM D229 (BORRACHA NITRIL)



44908-BO
N° ORIG.9.229.0.853.044.4

SAÍDA ESCAPAMENTO D226 /4



44704-FF
N° ORIG. 9.229.0.853.001.4

COLETOR ADMISSÃO MWM D225/226/229



44703-SC
N° ORIG. 6.207.0.853.007.4

GAXETA CANO ESCAPE F 1000/2000/4000



44900-A

RETENTOR DIANTEIRO



121V

RETENTOR TRASEIRO



124V

**MWM
D-229-6**

Nº CORTECO	DESCRIÇÃO DO JOGO
71106ECO	MWM D 229 6 CILS.F 1000 /2000 VW 11.130/ 13.130 ASP C/RETENTORES

Componentes do Jogo

- 44665-TD 1
- 44664-SC 6
- 44663-AN 1
- 44709-NT 1
- 44897-BO 6
- 44671-BO 1
- 44899-BO 1
- 44678-AN 2
- 44902-BO 1
- 44903-BO 1
- 44904-BO 1
- 44905-BO 1
- 44680-FF 1
- 44908-BO 1
- 44682-AN 1
- 44699-AN 1
- 44700-AN 1
- 44701-SC 6
- 44703-SC 6
- 44910-SI 12
- 124V 1
- 121V 1
- KA-44789 1

Quantidades

<p>COLETOR ADMISSÃO MWM D225/226/229</p> <p>44701-SC Nº ORIG. 6.321.3.853.009.4</p>	<p>COLETOR ADMISSÃO MWM D225/226/229</p> <p>44703-SC Nº ORIG. 6.207.0.853.007.4</p>	<p>VEDADOR BOMBA ALIMENTADORA</p> <p>44671-BO</p>	<p>VEDADOR 6 x 2</p> <p>44904-BO Nº ORIG. 6.0493.10.4.0062</p>
<p>VEDAÇÃO CAMISA MWM D229/TD229</p> <p>44910-SI Nº ORIG.6.0493.13.0.1124</p>	<p>VEDADOR O'RING 20 x 4</p> <p>44902-BO</p>	<p>VEDADOR O'RING 32 x 4</p> <p>44903-BO</p>	<p>TAMPA FRONTAL MWM D225/226/229</p> <p>44699-AN Nº ORIG.6.325.0.853.018.4</p>

CARTER MWM TD-229 6 CILS

44709-NT
Nº ORIG. 9.229.0.853.037.6

<p>BOMBA D'ÁGUA MWM D222/225/226/229</p> <p>44700-AN Nº ORIG.9.222.0.853.013.4</p>	<p>FILTRO AR</p> <p>44678-AN Nº ORIG. 9.229.0.853.014.4</p>	<p>CABEÇOTE MWM D229/TD229</p> <p>44665-TD</p>	<p>CABEÇOTE MWM D229/TD229</p> <p>44664-SC</p>	
<p>TAMPA DE VÁLVULA MWM D229 (BORRACHA NITRILICA)</p> <p>44908-BO Nº ORIG.9.229.0.853.044.4</p>	<p>ANEL 66 x 5.33</p> <p>44899-BO</p>	<p>JUNTA</p> <p>44682-AN Nº ORIG.9.225.0.853.009.4</p>	<p>RETENTOR DIANTEIRO</p> <p>121V</p>	<p>RETENTOR TRASEIRO</p> <p>124V</p>

CARTELA MWM 225 / 226 / 229 - 44663-AN

<p>BOMBA ALIMENTADORA</p> <p>Nº ORIG.6.321.4.853.012.4</p>	<p>TAMPA TRASEIRA</p> <p>Nº ORIG.6.325.0.853.005.4</p>	<p>SUPORTE BOMBA D'ÁGUA</p> <p>Nº ORIG.6.321.0.853.001.4</p>
<p>TAMPA INSPEÇÃO</p> <p>Nº ORIG.6.325.0.853.015.4</p>	<p>FILTRO LUBRIFICANTE</p> <p>71.633-AN Nº ORIG.9.305.0.853.021.4</p>	<p>BOMBA INJETORA</p> <p>Nº ORIG.6.205.0.853.012.4</p>

<p>ANEL 3.020.02B.00 20 x 2</p> <p>44897-BO</p>	<p>SAÍDA ESCAPAMENTO D229 /6</p> <p>44680-FF Nº ORIG.9.225.0.853.016.4</p>	<p>VEDADOR 42 x 3</p> <p>44905-BO ORIG. 6.0493.10.4.0423</p>
--	---	---

**KIT C/ 61 ARRUELAS
MWM D-229/4
KA-33789**

MWM
D-229-6 - SÉRIE TD

N° CORTECO

DESCRIÇÃO DO JOGO

71119ECO

MWM TD 229 6 CILS. Valmet 138/148 / Veicular VE/Ford C/Cabeçote SC/TV-BO/C/RETENTOR

Componentes do Jogo

- 33232-CI
- 44663-AN
- 44665-TD
- 44709-NT
- 44669-CV
- 44897-BO
- 44898-VI
- 44903-BO
- 44904-BO
- 44905-BO
- 44679-CV
- 44681-SC
- 44908-BO
- 44683-AN
- 44684-AN
- 44699-AN
- 44700-AN
- 44703-SC
- 44910-SI
- 44710-AN
- 44713-AN
- 44719-AN
- 33721-AN
- 44913-BO
- 124V
- 121V
- KA-33788

Quantidades

Componentes do Jogo	Quantidades	COLETOR ESCAPAMENTO/ ADMISSÃO MWM D229/TD229	COLETOR ADMISSÃO MWM D225/226/229	ENTRADA ÓLEO MWM TD229 4/6 CilS.	RETENTOR ÓLEO MWM TD 229 4/6CilS.
44679-CV N° ORIG. 9.229.0.853.029.4	1		44703-SC N° ORIG. 6.207.0.853.007.4	44719-AN	33721-AN
JUNTA RESFRIAD.DE ÓLEO	1		VEDADOR 6 x 2	VEDADOR O'RING 32 x 4	VEDADOR 14 x 3
44713-AN N° ORIG.9.229.0.853.051-4	1		44904-BO N° ORIG. 6.0493.10.4.0062	44903-BO	44913-BO
ANEL 3.025.04A.37	1		RETENTOR DIANTEIRO	RETENTOR TRASEIRO	VEDAÇÃO CAMISA MWM D229/TD229
44898-VI	1		121V	124V	44910-SI N° ORIG.6.0493.13.0.1124

KIT C/ 111 ARRUELAS MWM D-229/4 - KA-44788

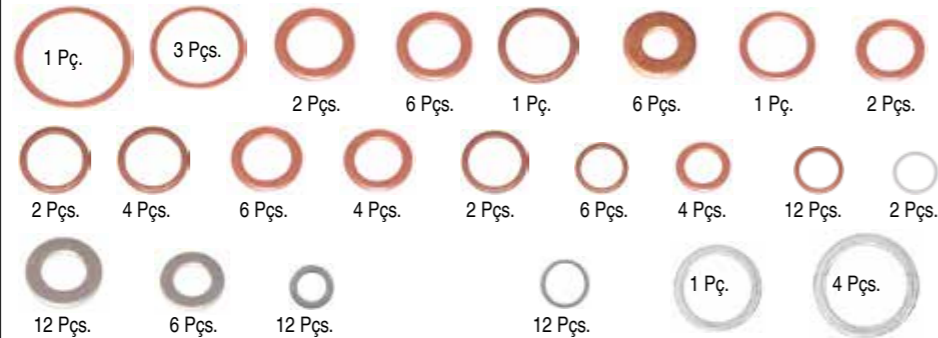

CABEÇOTE MWM D229/TD229



44665-TD

BOMBA D'ÁGUA MWM TURBO



44683-AN
N° ORIG.9.229.0.853.0224

CURVA ESCAPAMENTO



44681-SC
N° ORIG. 9.229.0.853.014.4



TAMPA RADIADOR ÓLEO
44684-AN
N° ORIG. 9.229.0.853.036.4

BOMBA D'ÁGUA MWM D222/225/226/229



44700-AN
N° ORIG.9.222.0.853.013.4

TAMPA DE VÁLVULA MWM D229 (BORRACHA NITRILICA)



44908-BO
N° ORIG.9.229.0.853.044.4

BASE TURBINA



33232-CL
N° ORIG.352.098.0280



TAMPA FRONTAL MWM D225/226/229
44699-AN
N° ORIG.6.325.0.853.018.4

LATERAL TURBINA



44669-CV

COMPLEMENTO CARTER 6CILS. AGRICOLA



44710-AN

VEDADOR 42 x 3



44905-BO
ORIG. 6.0493.10.4.0423

ANEL 3.020.02B.00 20 x 2



44897-BO

CARTELA MWM 225 / 226 / 229 - 44663-AN

BOMBA ALIMENTADORA



N° ORIG.6.321.4.853.012.4



TAMPA TRASEIRA
N° ORIG.6.325.0.853.005.4

SUPORE BOMBA D'ÁGUA



N° ORIG.6.321.0.853.001.4



TAMPA INSPEÇÃO
N° ORIG.6.325.0.853.015.4

FILTRO LUBRIFICANTE



71.633-AN
N° ORIG.9.305.0.853.021.4

BOMBA INJETORA



N° ORIG.6.205.0.853.012.4

MWM
410-4 / 610-6

Componentes do Jogo

22229-AI	1	1
33234-CV	1	
22622-AN	1	
44632-AN	1	
44723-NT	1	
44666-TD	4	6
44668-FF	4	6
44669-CV	1	
44670-SC	4	6
44672-SC	1	1
44673-SC	1	1
44674-FF	1	1
44677-SC	1	1
44685-AN	1	
44686-AN	1	
44687-AN	1	1
44689-AN	2	2
44691-AN	1	1
44693-AN	1	
44694-AN	1	1
44697-AN	1	1
44707-AN	1	1
44708-AN	1	1
44911-BO	4	6
44711-AN	1	1
44712-AN	1	
44912-VI	8	12
44714-SC	1	
44715-AN	1	
44717-AN	1	1
44719-AN	1	1
33721-AN	1	1
121V	1	1
7343V	1	1
7736V	8	12
KA-44794	1	
KA-44795	1	1
KB-44932	1	
KB-44933	1	

Nº CORTECO **DESCRIÇÃO DO JOGO**

71104ECO	MWM 410/ 4 C/ VEDADORES EM VITON C/ CABEÇOTE TD C/ RETENORES
71105ECO	MWM 610/6 C/ VEDADORES EM VITON C/ CABEÇOTE TD C/ RETENORES

CARCAÇA P/RESPIRO MWM 410/610 44694-AN Nº ORIG.9.610.0.853.004.4	CURVA SAÍDA ESCAPAMENTO MWM 410 4Cils. 44714-SC Nº ORIG.9.410.0.853.003.4	RETENOR DIANTEIRO 121V	LATERAL TURBINA D229 6Cils. 44669-CV
--	---	--------------------------------------	---

VEDAÇÃO CAMISA (VITON) MWM X-10 (7689) 44912-VI	RETENOR TRASEIRO 7343V	LATERAL TURBINA VW 7.110S/D20/VALMET 33234-CV
--	--------------------------------------	--

KIT C/30 ARRUELAS - MWM 410 - KA-44794

 1 Pç.	 1 Pç.	 4 Pçs.	 2 Pçs.
 10 Pçs.	 4 Pçs.	 2 Pçs.	 6 Pçs.

KIT BORRACHA MWM-X10 6Cils. - KB-44932

KIT BORRACHA MWM-X10 4Cils. KB-44933

ENTRADA ÓLEO
MWM TD 229 4/6Cils.

44719-AN

RETENOR ÓLEO
MWM TD 229 4/6Cils.

33721-AN

KIT C/34 ARRUELAS - MWM 610 - KA-44795

 6 Pçs.	 3 Pçs.	 15 Pçs.	 1 Pç.	 1 Pç.	 4 Pçs.	 4 Pçs.
------------	------------	-------------	-----------	-----------	------------	------------

RETENOR HASTE VÁLVULAS

7736V

CABEÇOTE
MWM 410/610 4/6Cils.TURBO

 44666-TD Nº ORIG. 9.610.854.14.4	CARTER MWM 410 4Cils. 44715-AN Nº ORIG.9.410.0.853.006.4	CARTER MWM 610 6Cils. 44717-AN Nº ORIG.9.610.0.853.018.4
TAMPA DISTRIBUIÇÃO DIANTEIRA MWM 410/610 4/6 Cils. 44707-AN Nº ORIG.9.410.0.853.004.4	TAMPA DISTRIBUIÇÃO DIANTEIRA MWM 610 6Cils. 44708-AN Nº ORIG.9.610.0.853.004.4	INTERCAMBIO CALOR MWM 410/610 44697-AN Nº ORIG.9.610.0.853.007.4
TAMPA DE VÁLVULA MWM 410/610 (ASPIRADO/TUBO) 44911-BO Nº ORIG.9.610.0.853.001	CURVA DO COLETOR ESCAP. 44673-SC	TAMPA DISTRIBUIÇÃO TRASEIRA - MWM 410/610 4/6Cils. 44711-AN Nº ORIG.9.410.0.853.005.4
BASE TURBINA (INOX) 22229-AI Nº ORIG.344.098.7080	BOMBA INJETORA 22622-AN Nº ORIG. 0.490.773	TAMPA DISTRIBUIÇÃO TRASEIRA - MWM 610 6Cils. 44712-AN Nº ORIG.9.610.0.853.006.4
FLANGE BOMBA ALIMENTORA 4.203/6.357 44632-AN Nº ORIG.36.862.152	COLETOR ESCAPAMENTO MWM 410/610 (INDIVIDUAL) 44668-FF Nº ORIG.9.610.853.0204	COLETOR ADMISSÃO MWM 410/610 (INDIVIDUAL) 44670-SC Nº ORIG.9.610.0.853.014.4
CURVA COLETOR ESCAPAMENTO MWM 610 6Cils. 44674-SC Nº ORIG.9.610.0.853.019.4	COLETOR ADMISSÃO MWM 610 6Cils. 44677-SC Nº ORIG. 9.610.0.853.022.4	BOCAL ENTRADA D'ÁGUA MWM 410 44685-AN Nº ORIG.9.410.0.853.021.4
BOCAL ENTRADA D'ÁGUA MWM 410/610 44687-AN Nº ORIG. 9.610.0.853.017.4	RADIADOR ÓLEO MWM 410/610 44689-AN Nº ORIG. 9.610.0.853.008.4	TERMOSTATO MWM 410/610 44691-AN Nº ORIG. 9.610.0.853.009.4
		CURVA COLETOR ADM. MWM 410 4Cils. 44672-SC Nº ORIG.9.410.0.853.002.4
		ALTERNADOR MWM 410/610 44693-AN Nº ORIG.9.610.0.853.013.4

**MWM
610 - 6 CILS**

Nº CORTECO **DESCRIÇÃO DO JOGO**

71103ECO MWM 610 C Cil. C/ CABEÇOTE TD E RETENTOR

Componentes do Jogo

- 22229-AI 1
- 44666-TD 4
- 44668-FF 4
- 44669-CV 1
- 44670-SC 6
- 44675-SC 1
- 44676-NT 1
- 44688-NT 1
- 44690-NT 2
- 44692-NT 1
- 44019-NT 1
- 44698-NT 1
- 44022-NT 1
- 44023-NT 1
- 44911-BO 6
- 44912-VI 12
- 44718-NT 1
- 44719-AN 1
- 44722-NT 1
- 44723-NT 1
- 44724-NT 1
- 121V 1
- 7343V 1
- 7736V 12
- KA-44796 1
- KB-44934 1

Quantidades

BASE TURBINA (INOX)



22229-AI
Nº ORIG.344.098.7080

LATERAL DA TURBINA 610 6Cils.



44669-CV

ANEL DA CAMISA (VITON) MWM 610



44912-VI

RETENTOR HASTE VÁLVULAS



7736V

RETENTOR DIANTEIRO



121V

RETENTOR TRASEIRO



7343V

KIT BORRACHA MWM 610 6Cils. - KB-44934

KIT COM 92 ARRUELAS MWM 610 6 Cils. - KA-44796

JUNTA DE VEDAÇÃO INTERMEDIÁRIA



44724-NT

CABEÇOTE MWM 610 6Cils.



44666-TD
Nº ORIG. 9.610.854.14.4

TAMPA DE VÁLVULA MWM 610 (ASPIRADO/TURBO)



44911-BO
Nº ORIG.9.610.0.853.001



CARTER MWM 610 6Cils.
44718-NT
Nº ORIG.9.610.0.853.018.4



TAMPA DISTRIBUIÇÃO DIANTEIRA MWM 410/610 4/6 Cils.
44022-NT
Nº ORIG.9.410.0.853.004.4



TAMPA DISTRIBUIÇÃO DIANTEIRA MWM 610 6Cils.
44023-NT
Nº ORIG.9.610.0.853.004.4

INTERCAMBIO CALOR MWM 610

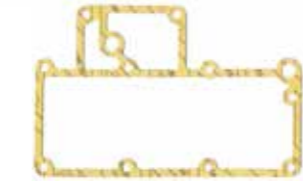

44698-NT
Nº ORIG.9.610.0.853.007.4

CURVA DA ADMISSÃO MWM 610 6Cils.



44676-NT
Nº ORIG. 9.610.0.853.022.4

INTERMEDIÁRIA DISTRIBUIDOR MWM X-10 2000/...



44723-NT
Nº ORIG. 9.410.8.853.024.4

CARÇAÇA P/RESPIRO MWM 610



44019-NT
Nº ORIG.9.610.0.853.004.4

COLETOR ESCAPAMENTO MWM 610 (INDIVIDUAL)



44668-FF
Nº ORIG.9.610.853.0204

COLETOR ADMISSÃO MWM 610 (INDIVIDUAL)



44670-SC
Nº ORIG.9.610.0.853.014.4

RADIADOR ÓLEO MWM 610



44690-NT
Nº ORIG. 9.610.0.853.008.4

TERMOSTATO MWM 410/610



44692-NT
Nº ORIG. 9.610.0.853.009.4

BOCAL ENTRADA D'ÁGUA MWM 610



44688-NT
Nº ORIG. 9.610.0.853.017.4

CURVA COLETOR ESCAPAMENTO MWM 610 6Cils.



44675-SC
Nº ORIG.9.610.0.853.019.4

ENTRADA ÓLEO MWM TD 229 4/6Cils.



44719-AN

RETENTOR ÓLEO MWM 610 6Cils.



44722-NT

MWM
ACTEON - 412 - 4 CILS.
/ 612 - 6 CILS.

Nº CORTECO **DESCRIÇÃO DO JOGO**

71412ECO	MWM 412 ACTEON 4 Cil. C/ CABEÇOTE MULTILAYER E RETENTOR
13860ECO	MWM 612 ACTEON 6 Cil. C/ CABEÇOTE MULTILAYER E RETENTOR
71413ECO	JOGO DE JUNTAS SUPERIOR BILINDRICO MWM 412 /612 ACTEON 4 /6CILS.

Componentes do Jogo

22229-AI	1	1
33234-CV	1	1
44887-BO		
44654-AN	1	
44667-ML	2	3
44668-FF	4	6
44669-CV		1
44670-SC	4	6
44688-NT	1	1
44690-NT	2	2
44691-NT	1	1
44694-NT	1	1
44695-AN	1	1
44696-SC	2	2
44698-NT	1	1
44911-BO	4	6
44912-VI	8	12
44716-NT	1	
44718-NT	1	
44720-NT	1	
44722-NT	1	
44725-NT	1	1
44726-NT	1	1
121V	1	1
7343V	1	1
7736V	8	12
KA-44798	1	1
44907-KB	1	
44909-KB	1	1
44723-NT	1	1

Quantidades



CARÇAÇA P/ RESPIRO MWM 610



44694-AN
Nº ORIG.9.610.0.853.004.4

RETORNO ÓLEO MWM 412 4 Cil.



44695-AN



44667-ML
Nº ORIG .9.612.0.854.003.4



44911-BO
ORIG.9.610.0.853.001



44668-FF
Nº ORIG.9.610.853.0204



44670-SC
Nº ORIG.9.610.0.853.014.4



7736V



TAMPA DISTRIBUIÇÃO MWM X-12
44726-NT
Nº ORIG.9.612.0.853.001.4



CARTER MWM 410/412 6Cils.
44716-NT
Nº ORIG.9 .610.0.853.006.4



CARTER MWM 610/612 6Cils.
44718-NT
Nº ORIG.9 .610.0.853.018.4



44723-NT
Nº ORIG. 9.410.8.853.024.4

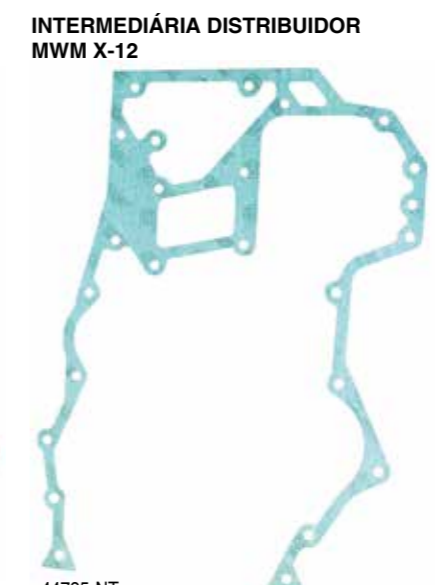

44725-NT
Nº ORIG. 9.612.8.853.024.4



44654-AN



44691-NT
Nº ORIG. 9.610.0.853.009.4



44722-NT



44696-SC
Nº ORIG. 9.610.0.853.009.4



44688-NT
Nº ORIG. 9.610.0.853.017.4



44690-NT
Nº ORIG. 9.610.0.853.008.4



44720-AN

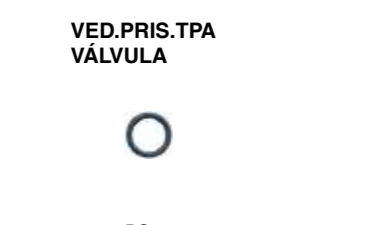

44887-BO

MWM SPRINT - 4.07 - 4 CILS. **MWM JOGOS DE RETIFICA VÁLVULAS - 1 CIL.**

Componentes do Jogo

- 44649-SC 1
- 8858V 1
- 9115V 1
- 9116V 12
- 44650-AN 1
- 44651-CB 1
- 44652-FF 4
- 44653-AN 1
- 44896-BO 1
- 44655-AN 1
- 44656-PP 1
- 44657-AN 1
- 44658-AN 1
- 44659-AN 1
- 44660-AN 1
- 44661-AN 1
- 44662-AN 1
- KA-44800 1
- KB-44906 1

Quantidades

Nº CORTECO **DESCRIÇÃO DO JOGO**

71004ECO MWM SPRINT (4.07 / 4.08 TCE 3.0) 4 CILS. C/ RETENTORES

CABEÇOTE MWM SPRINT (4.07) 4 CILS



44649-SC
Nº ORIG.9.407.0854.8074

TAMPA DE VÁLVULAS



44896-BO
Nº ORIG.9.407.0853.0034

CARTER MWM SPRINT (4.07) 4 CILS



44662-AN
Nº ORIG.9.407.0853.0014

COLETOR ADMISSÃO



44651-CB
Nº ORIG. 9.407.0853.0084

COLETOR ADMISSÃO



44650-AN
Nº ORIG. 9.407.0853.0164

REFRIGERADOR ÓLEO 4.08 TCE



44660-AN
Nº ORIG.9.408.0.853.0034

BOMBA INJETORA



44661-AN
Nº ORIG. 9.410.0853.0094

COLETOR ESCAPAMENTO



44652-FF
Nº ORIG. 9.607.0853.0084

JUNTA CURVA ADMISSÃO



44653-AN
Nº ORIG.9.407.0853.0054

REFRIGERADOR ÓLEO 4.08 TCE



44659-AN
Nº ORIG.9.408.0.853.0014

RETENTOR DIANTEIRO MWM SPRINT 4/6 CILS



8858V

RETENTOR TRASEIRO MWM SPRINT 4/6 CILS



9115V

RETENTOR HASTE VÁLVULAS MWM SPRINT 4/6 CILS



9116V

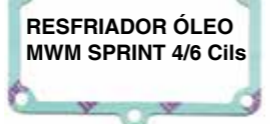

44655-AN
Nº ORIG. 9.407.0853.0094



CARÇAÇA TAMPA DISTRIBUIÇÃO
44656-PP
Nº ORIG.9.407.0853.0124

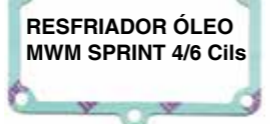

44655-AN
Nº ORIG. 9.407.0853.0094



BOMBA ÓLEO MWM SPRINT 4/6 CILS
44658-AN
Nº ORIG.9.407.0853.0184

KIT C/41ARRUELAS - MWM SPRINT 4Cils. - KA-44800

1 Pç. 4 Pçs. 16 Pçs. 1 Pç. 1 Pç.

1 Pç. 2 Pçs. 5 Pçs. 2 Pçs. 1 Pç.

1 Pç. 1 Pç. 4 Pçs. 1 Pç. 4 Pçs.

KIT BORRACHAS - MWM SPRINT 4Cils. - KB-44906

RESFRIADOR ÓLEO MWM SPRINT 4/6 CILS

44657-AN
Nº ORIG. 9.407.0853.0134

Nº CORTECO **DESCRIÇÃO DO JOGO**

71111ECO MOTOR MWM 410-4 / 610-6 (X-10)

CABEÇOTE MWM 410/610 4/6Cils.TURBO



44666-TD
Nº ORIG. .9.610.854.14.4

TAMPA DE VÁLVULA MWM 410/610 (ASPIRADO/TUBO)



44911-BO
Nº ORIG.9.610.0.853.001

COLETOR ESCAPAMENTO MWM 410/610 (INDIVIDUAL)



44668-FF
Nº ORIG.9.610.853.0204

COLETOR ADMISSÃO MWM 410/610 (INDIVIDUAL)



44670-SC
Nº ORIG.9.610.0.853.014.4

VED.PRIS.TPA VÁLVULA



44887-BO

ANEL VEDAÇÃO



44915-BO

RETENTOR HASTE VÁLVULAS



7736V

Nº CORTECO **DESCRIÇÃO DO JOGO**

71109ECO MOTOR MWM D-229 4/6 Cils.

CABEÇOTE MWM TD229/6



44665-TD

TAMPA DE VÁLVULA MWM D229 (BORRACHA NITRIL)



44908-BO
Nº ORIG.9.229.0.853.044.4

COLETOR ADMISSÃO MWM D225/226/229



44702-FF

COLETOR ADMISSÃO MWM D225/226/229



44703-SC
Nº ORIG. 6.207.0.853.007.4

ARRUELA



44759-AL 1,00mm

RETENTOR HASTE VÁLVULAS



7736V

ITENS AVULSOS
MWM

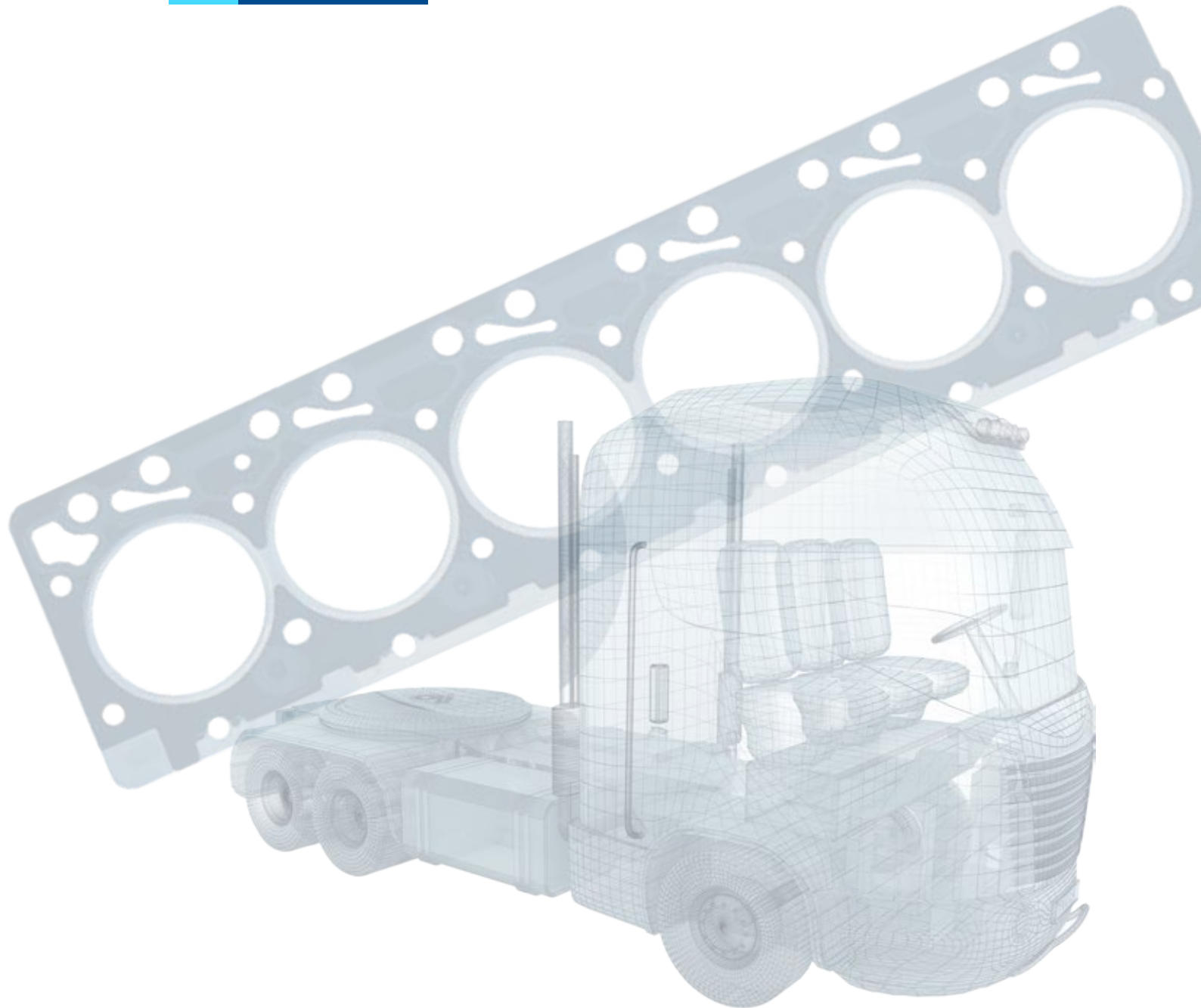

**MWM
AVULSOS**

APLICAÇÃO
MWM 906 6 CILINDROS.



CARTER
MWM 225/226/229 4Cils.

71716ECO-NT
N° ORIG.9.229.0.853.040.6

TAMPA DE VÁLVULA MWM D229
(BORRACHA NITRIL)



71127ECO-BO
N° ORIG.9.229.0.853.044.4

N° CORTECO **APLICAÇÃO**
71112ECO MWM D 229 4 CILS. VEICULAR F 1000 /2000 VW 6.90/7.90



CABEÇOTE
MWM D229/TD229

99972ECO-TD

TAMPA DE VÁLVULA MWM D229
(BORRACHA NITRILICA)



71127ECO-BO
N° ORIG.9.229.0.853.044.4



CARTER
MWM 225/226/229 4Cils.

71716ECO-NT
N° ORIG.9.229.0.853.040.6

N° CORTECO **APLICAÇÃO**
71105ECO MWM 610/6

CABEÇOTE
MWM 410/610 4/6Cils.TURBO



71102ECO-TD
N° ORIG .9.610.854.14.4

TAMPA DE VÁLVULA MWM
410/610 (ASPIRADO/TUBO)



75043ECO-BO
N° ORIG.9.610.0.853.001

N° CORTECO **APLICAÇÃO**
71106ECO MWM D 229 6 CILS.F 1000 /2000 VW 11.130/ 13.130 ASP

TAMPA DE VÁLVULA MWM D229
(BORRACHA NITRILICA)



71127ECO-BO
N° ORIG.9.229.0.853.044.4

CABEÇOTE
MWM D229/TD229



99972ECO-TD

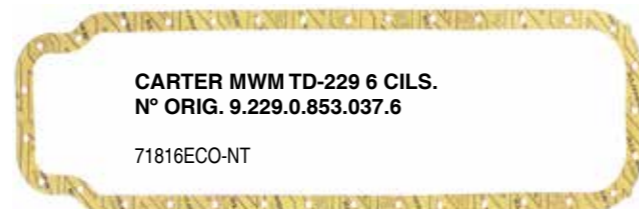

CARTER MWM TD-229 6 CILS.
N° ORIG. 9.229.0.853.037.6

71816ECO-NT

N° CORTECO **APLICAÇÃO**
71104ECO MWM 410/ 4

CABEÇOTE
MWM 410/610 4/6Cils.TURBO



71102ECO-TD
N° ORIG .9.610.854.14.4

TAMPA DE VÁLVULA MWM
410/610 (ASPIRADO/TUBO)



75043ECO-BO
N° ORIG.9.610.0.853.001

N° CORTECO **APLICAÇÃO**
71119ECO MWM TD 229 6 CILS. VALMET 138/148 / VEICULAR VE/FORD

TAMPA DE VÁLVULA MWM D229
(BORRACHA NITRILICA)



71127ECO-BO
N° ORIG.9.229.0.853.044.4

CABEÇOTE
MWM D229/TD229



99972ECO-TD

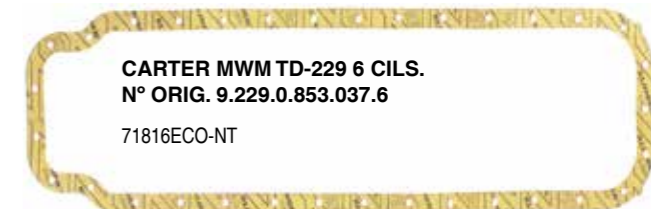

CARTER MWM TD-229 6 CILS.
N° ORIG. 9.229.0.853.037.6

71816ECO-NT

N° CORTECO **APLICAÇÃO**
71103ECO MWM 610 6 CILINDROS.

CABEÇOTE
MWM 410/610 4/6Cils.TURBO



71102ECO-TD
N° ORIG .9.610.854.14.4



CARTER MWM 610
6Cils.
71917ECO-NT
N° ORIG.9 .610.0.853.018.4

TAMPA DE VÁLVULA
MWM 610 (ASPIRADO/TURBO)



75043ECO-BO
N° ORIG.9.610.0.853.001

**MWM
AVULSOS**

N° CORTECO	APLICAÇÃO
71412ECO	MWM 412 ACTEON 4 CILINDROS
71413ECO	JOGO DE JUNTAS SUPERIOR BILINDRICO MWM 412 /612 ACTEON 4 /6CILINDROS



**CABEÇOTE
MWM X-12**
82412ECO-ML
N° ORIG .9.612.0.854.003.4



TAMPA DE VÁLVULA
75043ECO-BO
ORIG.9.610.0.853.001



CARTER MWM 410/412 6Cils.
71916ECO-NT
N° ORIG.9 .610.0.853.006.4

N° CORTECO	APLICAÇÃO
13860ECO	MWM 612 ACTEON 6 CILINDROS



CARTER MWM 610/612 6Cils.
71917ECO-NT
N° ORIG.9 .610.0.853.018.4



CABEÇOTE MWM X-12
82412ECO-ML
N° ORIG .9.612.0.854.003.4



TAMPA DE VÁLVULA
75043ECO-BO
ORIG.9.610.0.853.001

N° CORTECO	APLICAÇÃO
71004ECO	MWM SPRINT (4.07 / 4.08 TCE 3.0) 4 CILINDROS

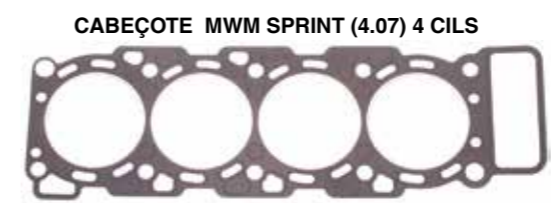

CABEÇOTE MWM SPRINT (4.07) 4 CILS
71002ECO-SC
N° ORIG.9.407.0854.8074

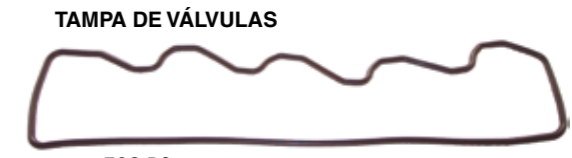

TAMPA DE VÁLVULAS
75962ECO-BO
N° ORIG.9.407.0853.0034



CARTER MWM SPRINT (4.07) 4 CILS
71096ECO-NT
N° ORIG.9.407.0853.0014

N° CORTECO	APLICAÇÃO
71111ECO	MOTOR MWM 410-4 / 610-6 (X-10)



**CABEÇOTE
MWM 410/610 4/6Cils.TURBO**
71102ECO-TD
N° ORIG .9.610.854.14.4



**TAMPA DE VÁLVULA MWM
410/610 (ASPIRADO/TUBO)**
75043ECO-BO
N° ORIG.9.610.0.853.001

N° CORTECO	APLICAÇÃO
71109ECO	MOTOR MWM D-229 4/6 CILINDROS.



CABEÇOTE MWM TD229/6
99972ECO-TD



**TAMPA DE VÁLVULA MWM D229
(BORRACHA NITRILICA)**
71127ECO-BO
N° ORIG.9.229.0.853.044.4

APLICAÇÃO

MOTOR MWM D-229 4 CILS. VEICULAR F1000/2000 VW 6.90/7.90

TAMPA DE VÁLVULA MWM D229
(CORTIÇA 6mm)



71126ECO-CB
Nº ORIG 9.229.0.853.006.4

APLICAÇÃO

MOTOR MWM D-229-6 - F600/F1000/F2000/F11000

JUNTA DO CARTER MWM D229/6

71816ECO-NT

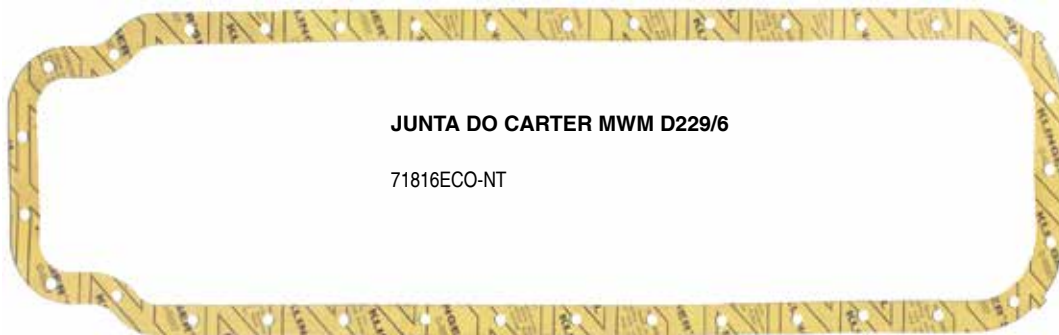

KITS DE JUNTAS **SCANIA**

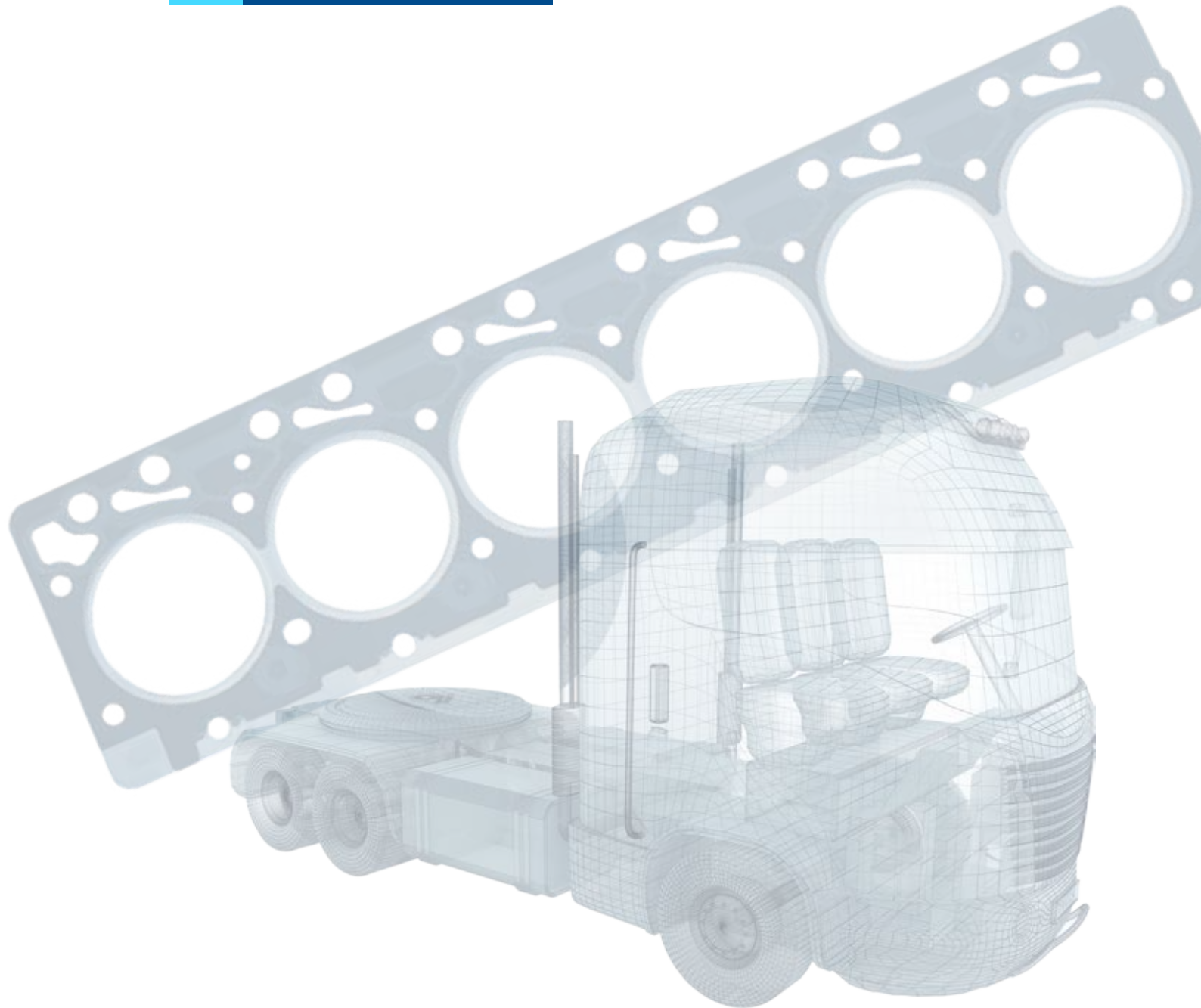

SCANIA
LK-140 / 141 / 142

N° CORTECO **DESCRIÇÃO DO JOGO**
59806ECO SCANIA LK 140/ 141 / 142 C/ CABEÇOTE

Componentes do Jogo

- 55809-BO 2
- 55311-BO 1
- 55362-BO 1
- 55363-BO 1
- 55780-BI 8
- 55851-AC 1
- 55378-AN 1
- 55379-AN 8
- 55380-GV 8
- 55381-SC 8
- 55852-BO 8
- 55382-GV 2
- 55383-AN 1
- 55384-AN 1
- 55385-AN 8
- 55386-GV 16
- 55387-AN 1
- 55388-AN 1
- 55389-GV 1
- 55390-AN 1
- 55392-GV 1
- 55393-SC 2
- 55394-GV 2
- 55395-GV 1
- 55396-SC 1
- 55397-AN 1
- 55398-AN 1
- 55399-AN 1
- 55400-AN 1
- 55401-GV 1
- 55402-GV 1
- 55403-GV 1
- 55404-GV 4
- 9119N 1
- 7672T 1
- 7343V 1
- 33405-BO 2
- 22853-BO 8
- 55854-BO 1
- 55406-BO 1
- 44902-BO 1
- GG-55924-SI 1
- KA-55785 1

Quantidades

RETENTOR TRASEIRO



7343V

RETENTOR DIANTEIRO



7672T

RETENTOR BOMBA INJETORA



9119N

JUNTA MANCAL / BALANCINS



55386-GV
N° ORIG.170.675

COLETOR ESCAPAMENTO



55381-SC
N° ORIG.277.607

COLETOR ADMISSÃO



55379-AN
N° ORIG.277.607

TAMPA CARÇAÇA DISTRIBUIÇÃO



55389-GV
N° ORIG. 170.916

JOGO TRAVAS SCANIA LK 140 - 55851-AC

TRAVA VOLANTE N° ORIG. 170.411	TRAVA PARAFUSOS VOLANTE N° ORIG.170.410	TRAVA N° ORIG.170.223
TRAVA EIXO BOMBA INJETORA	ARRUELA TRAVA	ARRUELA 28,3 x 45,5 TRAVA

KIT ARRUELAS C/82 Pçs. - KA-55785



CARTELA VEDADORES

VEDAÇÃO 90 x 3,0 55809-BO	VEDADOR 24,0 x 2,8 55311-BO	VEDADOR 27 x 3 55362-BO	VEDADOR 59 x 67 x 3,0 33405-BO
VEDADOR 117,0 x 3,5 55406-BO	VEDADOR 18,77 x 1,78 22853-BO	VEDADOR 21,8 x 3,5 55854-BO	VEDADOR O'RING 20 x 4 55403-BO
	VEDADOR O'RING ORIG. 7006.002.005.00.7 CG-55924-SI 31 x 3,0		VEDADOR TAMPA INFERIOR 72 x 3,5 55363-BO



CARÇAÇA BOMBA D'ÁGUA
55388-AN
N° ORIG.170.738



TAMPA LATERAL LK 140/141
55387-AN
N° ORIG.170.702



CARÇAÇA VOLANTE LK 140/141
55384-AN
N° ORIG.170.705



JUNTA
55397-AN
N° ORIG. 259.718



TAMPA TRAS. DISTRIBUIÇÃO
55398-AN
N° ORIG. 170.372

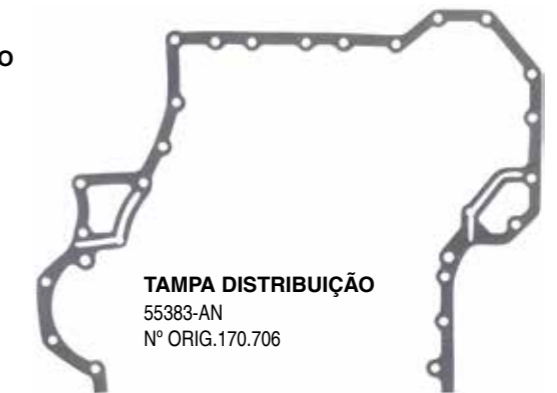

TAMPA DISTRIBUIÇÃO
55383-AN
N° ORIG.170.706



CABEÇOTE C/ANEIS INJETADOS
55780-BI
N° ORIG.1.313.459

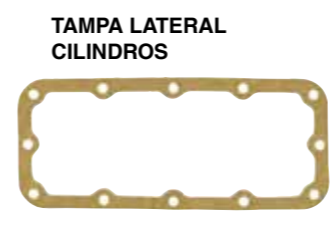

TAMPA LATERAL CILINDROS
55382-GV
N° ORIG.170.694



JUNTA COLUNA / TUBO ESCAPAMENTO
55396-SC
N° ORIG. 170.907



CARÇAÇA MED. GARGALO ENTRADA ÓLEO
55400-AN
N° ORIG: 170.937



TAMPA DE VÁLVULAS LK 140/141/142
55852-BO
N° ORIG.170.610



TAMPA CORPO BOMBA D'ÁGUA
55395-GV
N° ORIG. 170.686



VÁLVULA TERMOSTÁTICA
55394-GV
N° ORIG. 170.206



JUNTA TUBO D'ÁGUA
55380-GV
N° ORIG.170.368



SUPORTE BOMBA D'ÁGUA
55401-GV
N° ORIG. 170.668



SUPORTE BOMBA D'ÁGUA
55402-GV
N° ORIG. 170.687

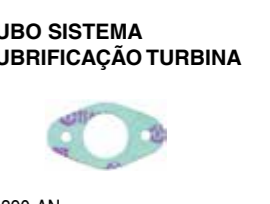

TUBO SISTEMA LUBRIFICAÇÃO TURBINA
55390-AN
N° ORIG.170.804



TAMPA D'ÁGUA AO BLOCO
55399-AN
N° ORIG.170.966



TAMPA LATERAL CABEÇOTE
55385-AN
N° ORIG.170.627



TUBO ADMISSÃO ESQUERDO
55403-GV
N° ORIG. 170.366



JUNTA TUBO ADMISSÃO
55392-GV
N° ORIG. 287.559



SUPERIOR TRASEIRO DIANTEIRO BLOCO
55404-GV
N° ORIG.170.696

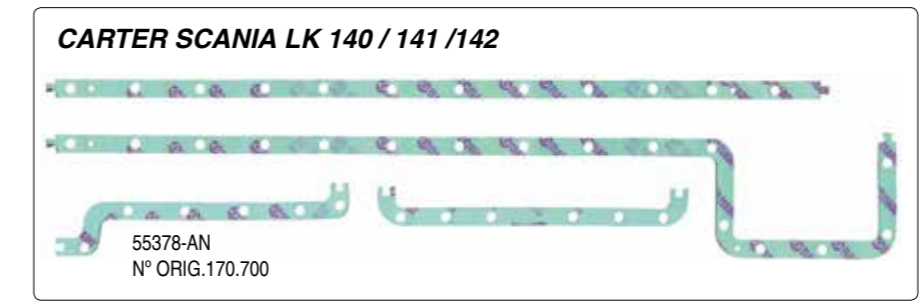

CARTER SCANIA LK 140 / 141 / 142

55378-AN
N° ORIG.170.700

SAÍDA ESCAPAMENTO



55393-SC
N° ORIG. 170.932

SCANIA
DSC-124
(360 / 420 / 420 E)

Nº CORTECO	DESCRIÇÃO DO JOGO
80901ECO	SCANIA DSC-124 92/98 - MOD. 360 C/RETENTOR
80903ECO	SCANIA DSC-124 MOD. 420 2002/... C/RETENTOR

Componentes do Jogo

55778-BI	6
55314-AN	1
55315-AN	1
55316-CV	1
55317-CV	1
55777-BI	6
55323-AN	1
55840-BO	1
55324-AN	6
55325-SC	6
55326-AN	6
55327-ML	6
55328-AN	1
55329-AN	1
55330-AN	1
55331-AN	1
55332-AN	1
55333-AN	1
55334-AN	1
55335-AN	1
55336-AN	3
55337-AN	3
55841-BO	1
55338-AN	1
55842-BO	6
55339-AN	1
55340-AN	1
55341-AN	1
55342-AN	1
55343-AN	1
55847-BO	1
55844-BO	1
55845-BO	1
55846-BO	1
22853-BO	24
3248T	1
3250T	1
7667V	24
55839-BO	2
55838-BO	2
KA-55801	1

KIT BORRACHA - 55845-BO

FILTRO ROTATIVO
Nº ORIG. 1.496.381

KIT BORRACHA 55845-BO
RADIADOR DE ÓLEO
Nº ORIG. 1.349.497

FILTRO ÓLEO
Nº ORIG. 1.367.849

BOMBA D'ÁGUA
Nº ORIG. 1.403.883

VEDADOR DO TUBO DE VENTILAÇÃO DO CARTER
Nº ORIG. 1.401.985

TUBO ADMISSÃO
Nº ORIG. 1.390.211

VEDADOR 31,5 x 4,10mm
55838-BO

VEDADOR 49,20 x 4,10mm
55839-BO

JUNTA DE VEDAÇÃO DA BOMBA PRIMÁRIA
55847-BO

DIANTEIRO VIRABREQUIM
3248T

RADIADOR ÓLEO 2002/...
55844-BO
Nº ORIG. 1.433.886

RETENTOR HASTE VÁLVULAS
7667V

TAMPA LATERAL 2002/...
55841-BO
Nº ORIG. 1.445.514

KIT TURBINA

55314-AN

55315-AN

55316-CV

55317-CV
Nº ORIG. 1.393.937

RETENTOR TRASEIRO VIRABREQUIM
3250T

KIT DE ANEIS 55846-BO

KIT ARRUELA KA-55801
KIT COM 73 ARRUELAS

CABEÇOTE (C/ANEIS INJETADOS)

55777-BI
Nº ORIG. 1377039

360

55840-BO
Nº ORIG. 1.367.028

55840-BO
Nº ORIG. 1.367.027

360/420

55842-BO
Nº ORIG. 1.411.851

55842-BO
Nº ORIG. 1.476.506
1.401.982

55842-BO
Nº ORIG. 1.414.422

CABEÇOTE (C/ANEIS INJET.) 124 400EV/420 ELETRÔNICO

55778-BI
Nº ORIG. 1.468.555

COLETOR ADMISSÃO 124 400EV/420

55327-ML
Nº ORIG. 1.524.474

COLETOR ADMISSÃO

55324-AN
Nº ORIG. 1374338

COLETOR ADMISSÃO

55326-AN
Nº ORIG. 1374340

COLETOR ESCAPE

55325-SC
Nº ORIG. 1309051

TUBO ADMISSÃO

55334-AN
Nº ORIG. 1374342

CARTER
55323-AN
Nº ORIG. 1.460.359

TAMPA LATERAL
55337-AN
Nº ORIG. 1.375.383

TAMPA LATERAL
55336-AN
Nº ORIG. 1.374.326

TAMPA DISTRIBUIÇÃO VENTILAÇÃO AO CARTER
55343-AN
ORIG. 1.403.129

TAMPA DISTRIBUIÇÃO VENTILAÇÃO AO CARTER
55335-AN
Nº ORIG. 1.374.334

TUBO SENSOR TEMPERATURA
55338-AN
Nº ORIG. 1374346

VEDADOR TUBO INJETOR
22853-BO
Nº ORIG. 1340615

TUBULAÇÕES E MANGUEIRA

55332-AN
Nº ORIG. 1374336

BOMBA D'ÁGUA
55329-AN
Nº ORIG. 1374344

CAIXA DISTRIBUIÇÃO

55339-AN
Nº ORIG. 1375387

BOMBA HIDRÁULICA

55331-AN
Nº ORIG. 1374346

CAIXA DISTRIBUIÇÃO MOTRIZ
55330-AN
Nº ORIG. 1374327

CARÇAÇA TERMOSTATO

55328-AN
Nº ORIG. 1374333

RADIADOR ÓLEO

55340-AN
Nº ORIG. 1391726

FILTRO D'ÁGUA

55333-AN
Nº ORIG. 1374517

CANO DO ÓLEO

55341-AN
Nº ORIG. 1.375.992

BOCAL VARETA ÓLEO

55342-AN
Nº ORIG. 1.374.330

SCANIA
RETIFICA VÁLVULA
1 CIL.

SCANIA
RETIFICA VÁLVULA
1 CIL. SERIE 5

Nº CORTECO **DESCRIÇÃO DO JOGO**
59501ECO DSC 124 (360) C/RETENTOR

COLETOR ADMISSÃO



55324-AN
Nº ORIG. 1374338

COLETOR ESCAPE



55325-SC
Nº ORIG. 1309051

COLETOR ADMISSÃO



55326-AN
Nº ORIG. 1374340

VEDADOR ENTRE TAMP/CABEÇOTE



11923-AC
Nº ORIG. 1374842

VEDADOR COLETOR COMBUSTIVEL/TUBO RET.

55843-BO
Nº ORIG. 1.368.061



RETENTOR HASTE VÁLVULAS



7667V

VEDADOR TUBO INJETOR

22853-BO
Nº ORIG. 1340615



CABEÇOTE (C/ANEIS INJET.) 124 400EV/420 ELETRÔNICO

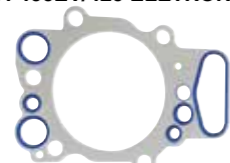

55778-BI
Nº ORIG. 1.468.555

ARRUELA DE VEDAÇÃO DO BICO INJETOR



55757-CU200

SCANIA 124 (360) 55840-BO

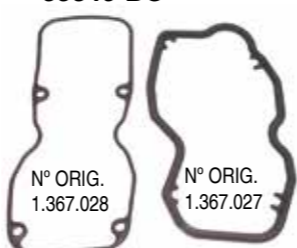

Nº ORIG. 1.367.028

Nº ORIG. 1.367.027

Nº CORTECO **DESCRIÇÃO DO JOGO**
59505ECO DSC 124-400EV / 420 ELETRÔNICO 2002/... C/RETENTOR

RETENTOR HASTE VÁLVULAS



7667V

CABEÇOTE (C/ANEIS INJET.) 124 400EV/420 ELETRÔNICO



55778-BI
Nº ORIG. 1.468.555

VEDADOR COLETOR COMBUSTIVEL/TUBO RET.

55843-BO
Nº ORIG. 1.368.061



124 400EV/420 ELETRÔNICO 55842-BO



Nº ORIG. 1.411.851

Nº ORIG. 1.476.506

Nº ORIG. 1.414.422

VEDADOR ENTRE TAMP/CABEÇOTE



11923-AC
Nº ORIG. 1374842

ARRUELA DE VEDAÇÃO DO BICO INJETOR



55757-CU200

COLETOR ESCAPE



55325-SC
Nº ORIG. 1309051

COLETOR ADMISSÃO 124 400EV/420 ELETRÔNICO



55327-ML
Nº ORIG. 1.524.474

Nº CORTECO **DESCRIÇÃO DO JOGO**
59509ECO DSC 124 SERIE 5 C/RETENTOR

CABEÇOTE (C/ANEIS INJET.) 124 400EV/420 ELETRÔNICO

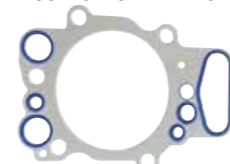

55778-BI
Nº ORIG. 1.468.555

TAMPA DE VÁLVULA SUPERIOR



55319-SI
Nº ORIG. 1.505.366

TAMPA DE VÁLVULA INFERIOR



55320-SI
Nº ORIG. 11.449.542

RETENTOR HASTE VÁLVULAS



7667V

ARRUELA DE VEDAÇÃO DO BICO INJETOR



55757-CU200

VEDADOR COLETOR COMBUSTIVEL/TUBO RET.



55321-BO
Nº ORIG. 1.390.083

COLETOR ESCAPE



55325-SC
Nº ORIG. 1309051

VEDADOR ENTRE TAMP/CABEÇOTE



11923-AC
Nº ORIG. 1374842

VEDADOR COLETOR COMBUSTIVEL/TUBO RET.























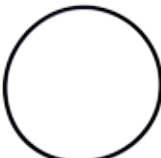





55843-BO
Nº ORIG. 1.368.061

COLETOR ADMISSÃO 124 400EV/420 ELETRÔNICO



55327-ML
Nº ORIG. 1.524.474

Componentes do Jogo		Nº CORTECO	DESCRIÇÃO DO JOGO			
		80112ECO	SCANIA 112 / 113 C/RETENTOR E ANEIS CAMISA (UNIFICADO)			
55941-CI	2	JUNTA DO SUPORTE DOS BALANCINS	JUNTA DO COLETOR DE ESCAPE	JUNTA DA TAMPA DA CARÇAÇA DO TERMOSTATO	JUNTA DO COLETOR DE ESCAPAMENTO	
55942-NT	6					
55943-GV	2					
55944-CI	2					
55945-BO	1	55942-NT	55941-CI	55943-GV	55944-CI	
55946-BO	1					
55363-BO	1					
55947-AN	1	JUNTA DA TAMPA DA CAMARA TERMOSTÁTICA	JUNTA DO CORPO DA BOMBA DE ÓLEO	JUNTA DE VEDAÇÃO		
55948-CI	1					
55949-GV	1					
55950-NT	2	55950-NT	55951-PP	55949-GV		
55951-PP	1					
55952-BO	2	JUNTA DA SAÍDA DO ESCAPAMENTO	ANEL DE VEDAÇÃO	VEDADOR DA TAMPA INFERIOR	ANEL DA CAMISA - CINTA	
55953-BO	1					
33848-BO	1					
55954-BO	1					
55955-BO	1					
55956-VI	6					
55957-BO	1					
55958-BO	1					
88027-BO	1					
55959-BO	1					
55960-BO	1					
44913-BO	2					
55961-BO	3					
55962-SI	1					
		JUNTA DO FILTRO ROTATIVO	ANEL DE VEDAÇÃO	ANEL DE VEDAÇÃO	ANEL DE VEDAÇÃO	ANEL DE VEDAÇÃO
						
		55947-AN	55955-BO	55954-BO	55957-BO	55959-BO
		ANEL DE VEDAÇÃO	ANEL DE VEDAÇÃO	ANEL DE VEDAÇÃO	ANEL DE VEDAÇÃO	ANEL DE VEDAÇÃO
						
		55962-SI	44913-BO	55958-BO	33848-BO	55952-BO
		VEDADOR	VEDADOR	VEDADOR	VEDADOR	VEDADOR DA TAMPA DE VÁLVULA
						
		55961-BO	55960-BO	55945-BO	88027-BO	55946-BO

ITENS AVULSOS
SCANIA

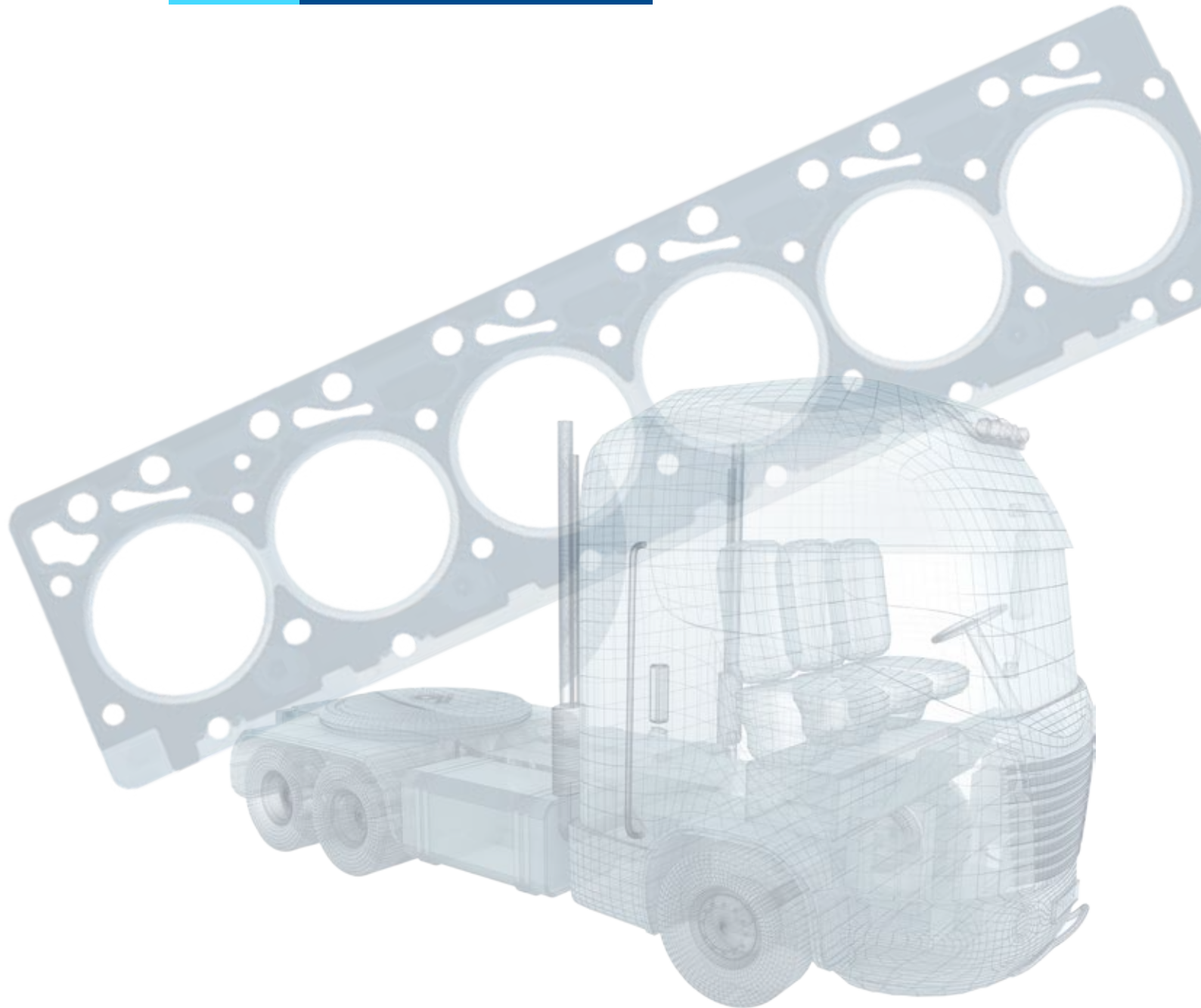

**SCANIA
AVULSOS**

N° CORTECO	APLICAÇÃO
80112ECO	SCANIA 112 / 113

**CARTER SCANIA L75/76/110/111/112
59616ECO-AN**



N° ORIG. 215.242

CABEÇOTE SCANIA L100/111/112/113

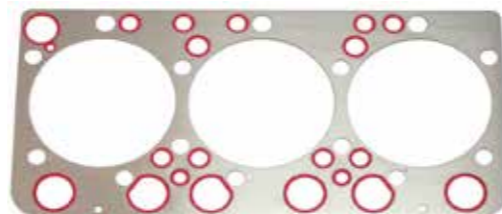

99961ECO-BI
N° ORIG. 373.472/257.375

**TAMPA DE VÁLVULA
SCANIA L75/76/110/111/ 12**

59626ECO-CB
N° ORIG. 131.039 /258.459

N° CORTECO	APLICAÇÃO
80901ECO	SCANIA DSC-124 92/98 - MOD. 360

SCANIA 124 (360) - 75651ECO-BO

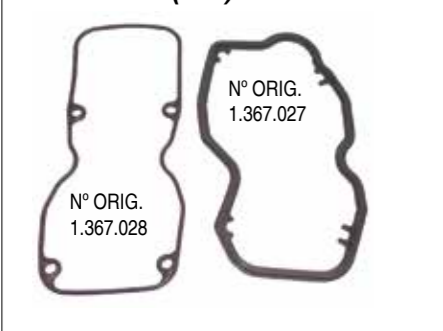

N° ORIG. 1.367.027

N° ORIG. 1.367.028

CARTER
96224ECO-AN
N° ORIG. 1.460.359



SCANIA 124 (360) - 75651ECO-BO

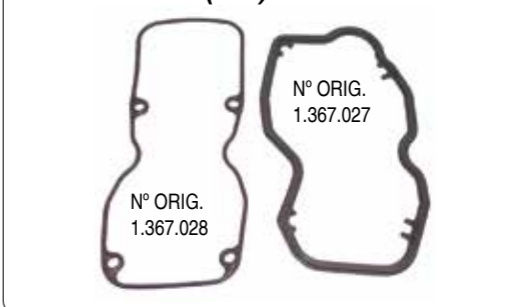

N° ORIG. 1.367.027

N° ORIG. 1.367.028

N° CORTECO	APLICAÇÃO
80902ECO e 80903ECO	SCANIA DSC-124 MOD. 420

360/420 - 75655ECO-BO

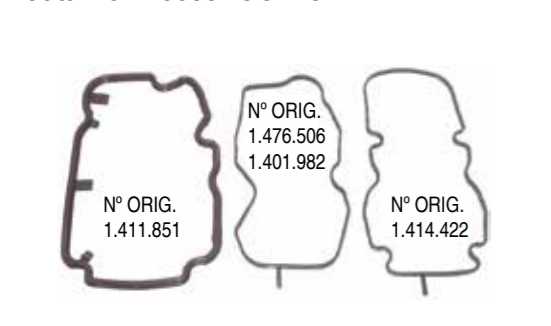

N° ORIG. 1.476.506
1.401.982

N° ORIG. 1.411.851

N° ORIG. 1.414.422

CARTER
96224ECO-AN
N° ORIG. 1.460.359



**CABEÇOTE (C/ ANÉIS INJETADOS)
124 400EV/420 ELETRÔNICO**

25830ECO-BI
N° ORIG. 1.468.555

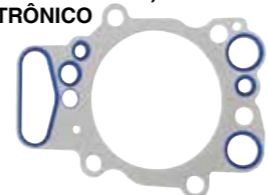

N° CORTECO	APLICAÇÃO
59509ECO	SCANIA 112 / 113 DSC 124 SERIE 5

**CABEÇOTE (C/ANEIS INJETADO)
124 400EV/420 ELETRÔNICO**

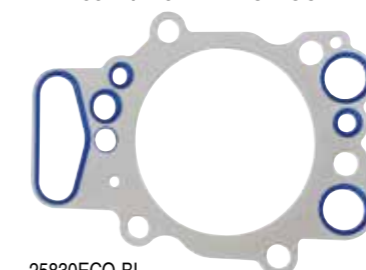

25830ECO-BI
N° ORIG. 1.468.555

N° CORTECO	APLICAÇÃO
59501ECO	DSC 124 (360)

SCANIA 124 (360) - 75651ECO-BO

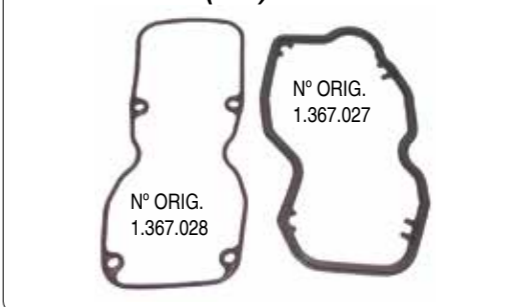

N° ORIG. 1.367.027

N° ORIG. 1.367.028

N° CORTECO	APLICAÇÃO
59504ECO 59505ECO	DSC 124 (420) C/RETENTOR DSC 124-400EV / 420 ELETRÔNICO

**CABEÇOTE (C/ ANÉIS INJETADOS)
124 400EV/420 ELETRÔNICO**

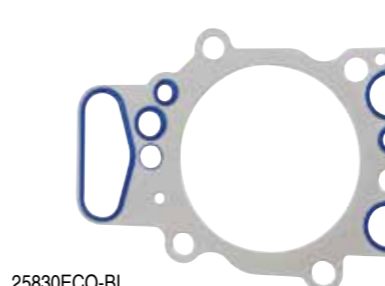

25830ECO-BI
N° ORIG. 1.468.555

SCANIA 124 (420) - 75655ECO-BO

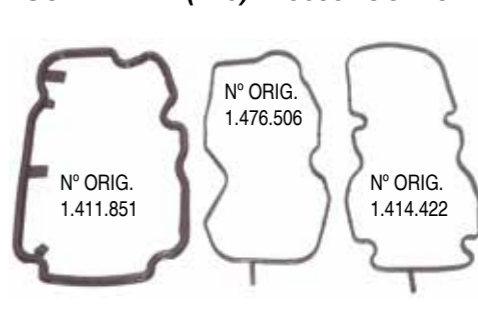

N° ORIG. 1.476.506

N° ORIG. 1.411.851

N° ORIG. 1.414.422

N° CORTECO

59806ECO

APLICAÇÃO

SCANIA LK 140/ 141 / 142

CARTER SCANIA LK 140 / 141 /142
01652ECO-AN

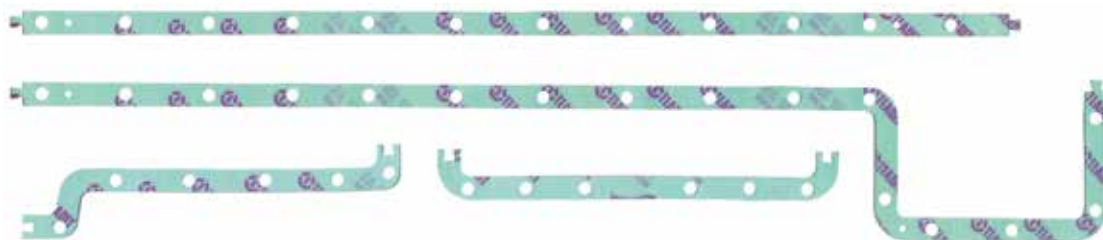

N° ORIG.170.700

CABEÇOTE C/ ANÉIS
INJETADOS

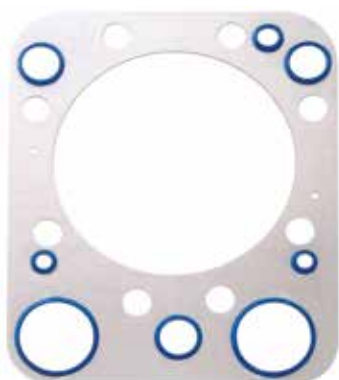

93472ECO-BI
N° ORIG.1.313.459

TAMPA DE VÁLVULAS
LK 140/141/142



01393ECO-BO
N° ORIG.170.610

KITS DE JUNTAS **VALTRA**

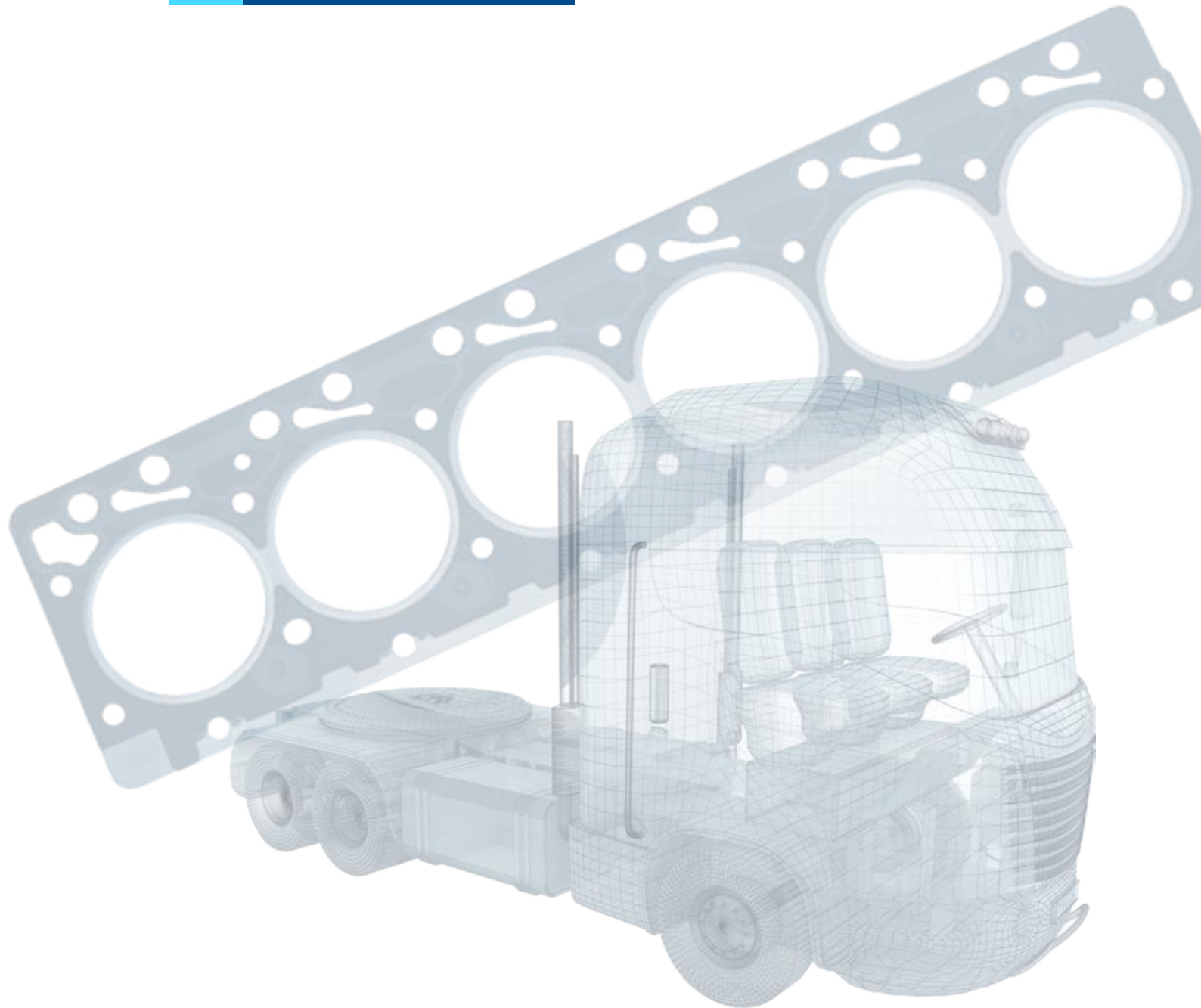

VALTRA
320 DS 3 CILS.

N° CORTECO

DESCRIÇÃO DO JOGO

73320ECO

VALTRA 320 3 CILS. C/RETENORES

Componentes do Jogo

- 22622-AN
- 66727-AN
- 66729-AN
- 66731-CB
- 66733-ML
- 66734-CB
- KA-66802
- 66916-BO
- 66917-SI
- 66918-BO
- 66919-BO
- 66920-BO
- 66921-BO
- 66922-BO
- 66740-AN
- 66741-AN
- 66742-AN
- 66743-AN
- 66744-AN
- 66745-AN
- 66747-AN
- 66748-AN
- 66750-SC
- 66753-FF
- 66754-PP
- 66755-SC
- 7757V
- 9123T
- 9122P

- 1
- 1
- 1
- 1
- 1
- 1
- 6
- 3
- 2
- 3
- 2
- 2
- 1
- 1
- 1
- 1
- 1
- 1
- 1
- 1
- 1
- 1
- 2
- 1
- 1
- 1
- 1
- 8
- 1
- 1

Quantidades

VEDADOR
10,5 x 21 x 8



66918-BO

VEDADOR
15 x 2,5



66920-BO

RETENTOR DIANTEIRO



9122P
N° ORIG. 614105880

VEDADOR ANEL CAMISA
114 x 3,5

66916-BO
N° ORIG. 836647502

VEDADOR
20 x 28,5 x 7



66919-BO

VEDADOR
30 x 5



66921-BO

VEDADOR ANEL CAMISA
114 x 3,5

66917-SI
N° ORIG. 836647503

VEDADOR
47 x 4



66922-BO

RETENTOR TRASEIRO

9123T
N° ORIG. 614500002

JUNTA DO TUBO DE ESCAPE



66755-SC

KIT ARRUELAS VALTRA 3 CILS.
KA-66802

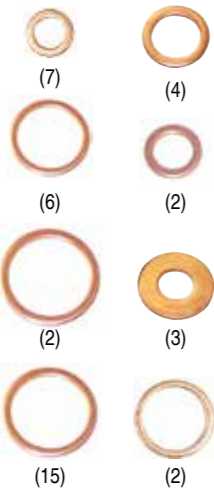

CARTELA JUNTAS VALTRA 3/4/6 CILS.
66729-AN



CABEÇOTE 320 3CILS.



66733-ML
N° ORIG. 837070290

TAMPA DE VÁLVULA
3/6 CILS.



66731-CB
N° ORIG. 836646360



TAMPA DISTRIBUIÇÃO
ENGRENAGEM 3/4/6 CILS.

66740-AN
N° ORIG. 836647419

BOMBA INJETORA



22622-AN
N° ORIG. 0.490.773

BOMBA D'ÁGUA



66744-AN
N° ORIG. 836120128

CARTER



66734-CB
N° ORIG. 836006704

TAMPA TRASEIRA CABEÇOTE
3/6 CILS.



66750-SC
N° ORIG. 836855417

JUNTA DA TURBINA.



66753-FF



TAMPA DISTRIBUIÇÃO
FRONTAL VALTRA 3/4/6 CILS.

66741-AN
N° ORIG. 83536796

COLETOR ADMISSÃO
3/6 CILS.

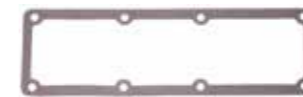

66727-AN
N° ORIG. 836847496

VÁLVULA TERMOSTÁTICA



66742-AN
N° ORIG. 836119849

CARCAÇA VÁLVULA
TERMOSTÁTICA



66743-AN
N° ORIG. 836649343

TAMPA ROLAMENTO



66747-AN
N° ORIG. 835336793

BOMBA ÓLEO



66754-PP
N° ORIG. 836014198

TAMPA DIANTEIRA



66748-AN
N° ORIG. 836129946

RETENTOR HASTE
VÁLVULAS



7757V

RESFRIADOR ÓLEO



66745-AN
N° ORIG. 836120129

KITS DE JUNTAS **VOLVO**

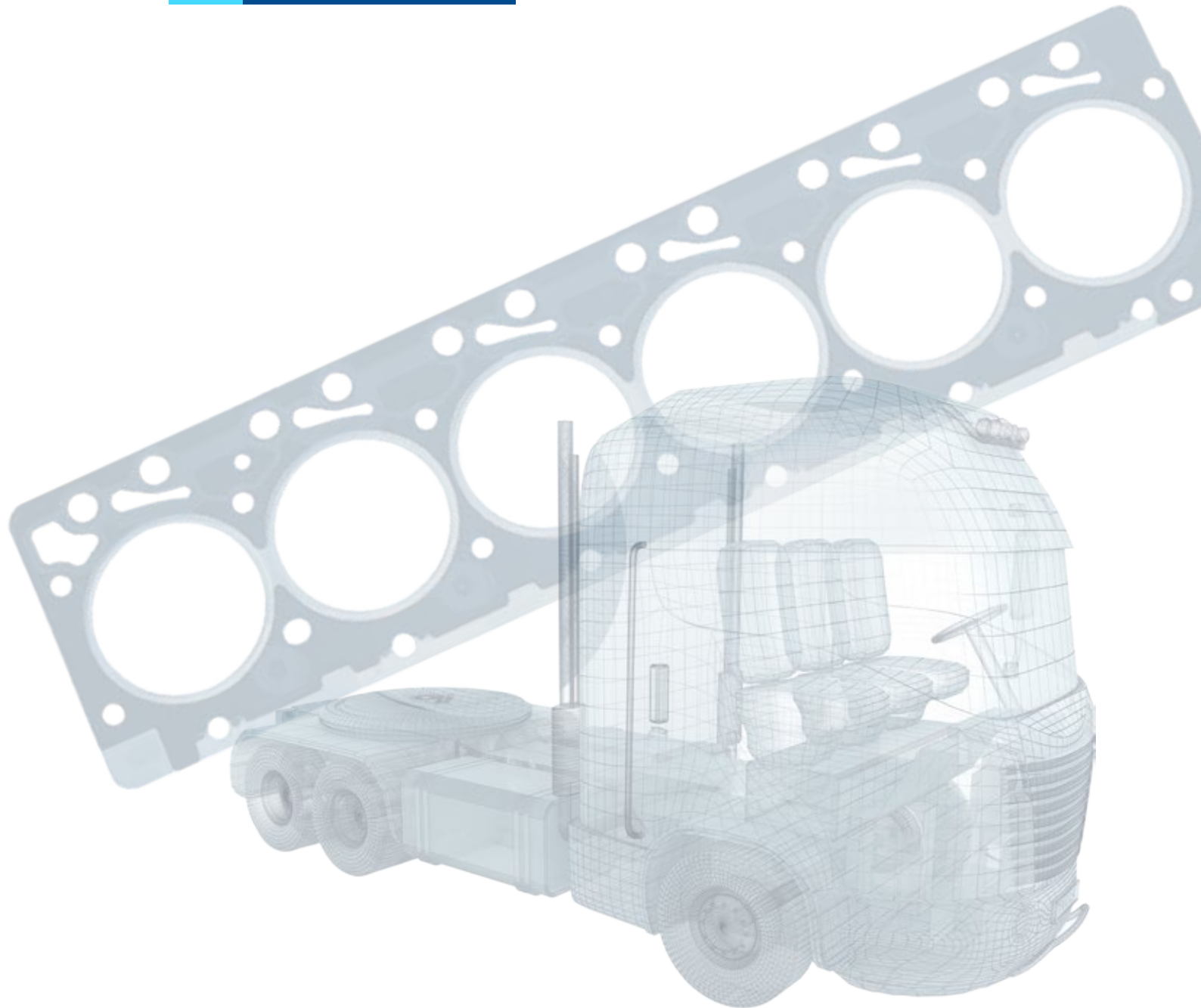

VOLVO
NL-10 / TD-102F
102FS / NL-10 EDC

N° CORTECO **DESCRIÇÃO DO JOGO**

80320ECO VOLVO NL-10 / TD-102F / 102FS
17060ECO VOLVO NL-10 EDC C/RETENORES

Componentes do Jogo

77129-GA	1	1
77130-GA	1	1
77132-GA	1	1
77135-BO	3	3
77145-OR	6	6
77146AN	1	1
77149-FF-BO	1	1
77134-GA	1	1
77150-CV-AN	1	1
77153-BO	1	1
7440V	1	1
1243V	1	1
KA-77929	1	1
KA-77930	1	1
KB-77949	1	1
KB-77950	1	1

Quantidades



RETENTOR TRASEIRO

1243V

RETENTOR DISTRIBUIÇÃO



7440V

JOGO TURBINA
77150-CV-AN



KIT BORRACHAS NL-10 / TD-102F / 102FS
KB-77950



COLETOR ESCAPAMENTO E ADMISSÃO
77149-FF-BO

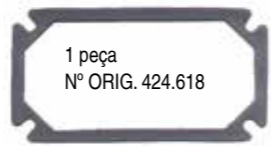

77153-BO



KIT BORRACHAS - NL-10 EDC
KB-77949

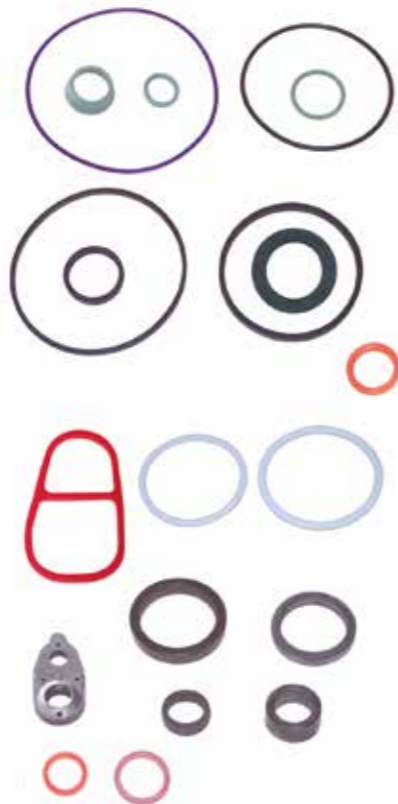

JUNTA DO CARTER

77146-AN
N° ORIG. 424.127



NL-10 / TD-102F / 102FS
KA-77930



KIT ARRUELAS NL-10 EDC
KA-77929



TAMPA DISTRIBUIÇÃO

77129-GA
N° ORIG. 468.116

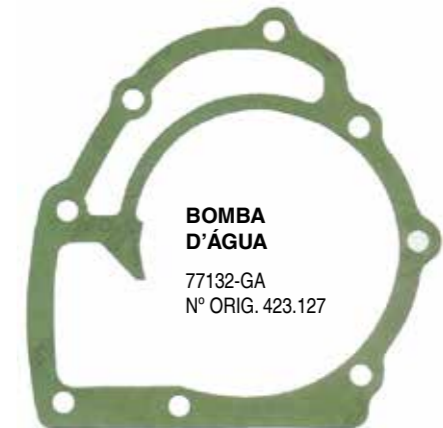

BOMBA D'ÁGUA

77132-GA
N° ORIG. 423.127



TAMPA DISTRIBUIÇÃO

77130-GA
N° ORIG. 468.557



TAMPA LATERAL DOS TUCHOS

77135-BO
N° ORIG. 469.823

CABEÇOTE C/ INSERTOS



77145-OR
N° ORIG. 270.789.0

VOLVO
N-12 / TD-122FS
NL-12 EDC

N° CORTECO **DESCRIÇÃO DO JOGO**

80322ECO	VOLVO NL-12 / TD122FS C/ RETENTORES
80321ECO	VOLVO NL-12 EDC C/RETENTORES

Componentes do Jogo

77129-GA	1	1
77131-GA	1	1
77133-GA	1	1
77135-BO	3	3
77147-OR	6	6
77148-AN	1	1
77149-FF-BO	1	1
77152-BO	6	6
77151-CV-AN	1	1
7440V	1	1
1243V	1	1
KA-77928	1	1
KA-77931	1	1
KB-77951	1	1
KB-77952	1	1

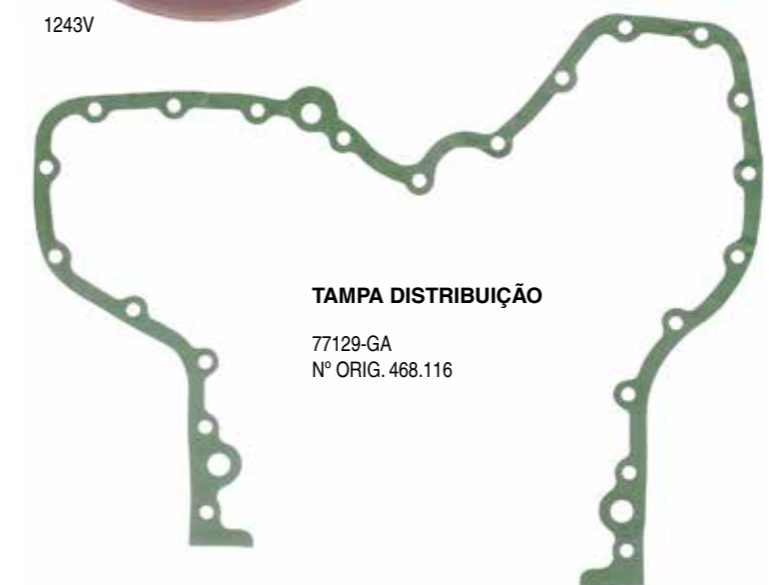
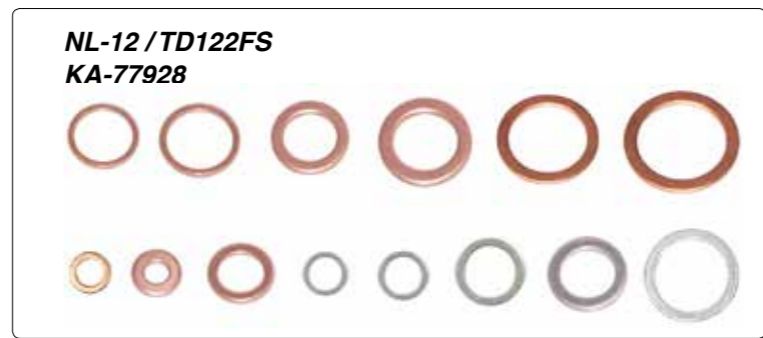
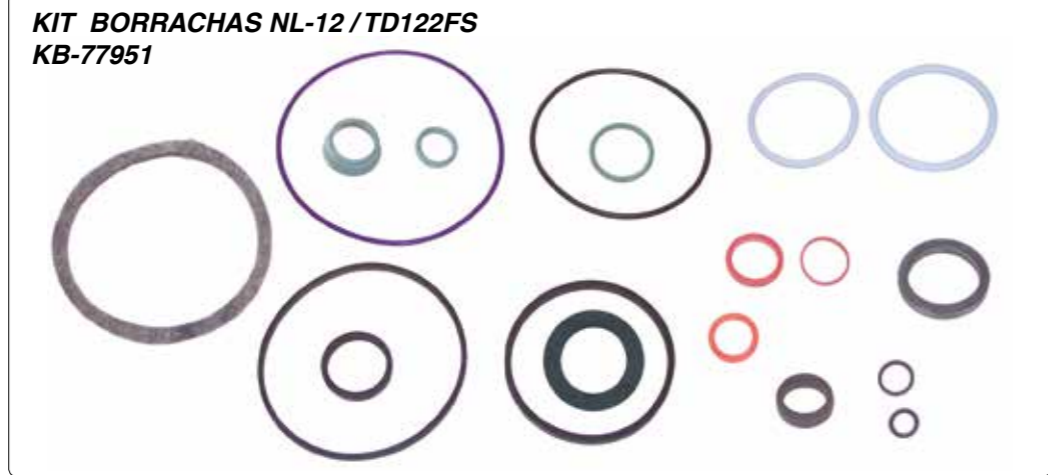

VOLVO FH-12

N° CORTECO	DESCRIÇÃO DO JOGO
49012ECO	VOLVO FH-12 C/ RETENORES

Componentes do Jogo

- 77776-BI
- 77127-BO
- 77128-BO
- 77136-BO
- 77137-BO
- 77138-BO
- 77140-BO
- 77139-BI
- 77141-BO
- 77142-BI
- 77144-KT
- 77143-KB
- KA-77805
- 7441V
- 8425V

Quantidades

**KIT BORRACHAS
77143-KB**

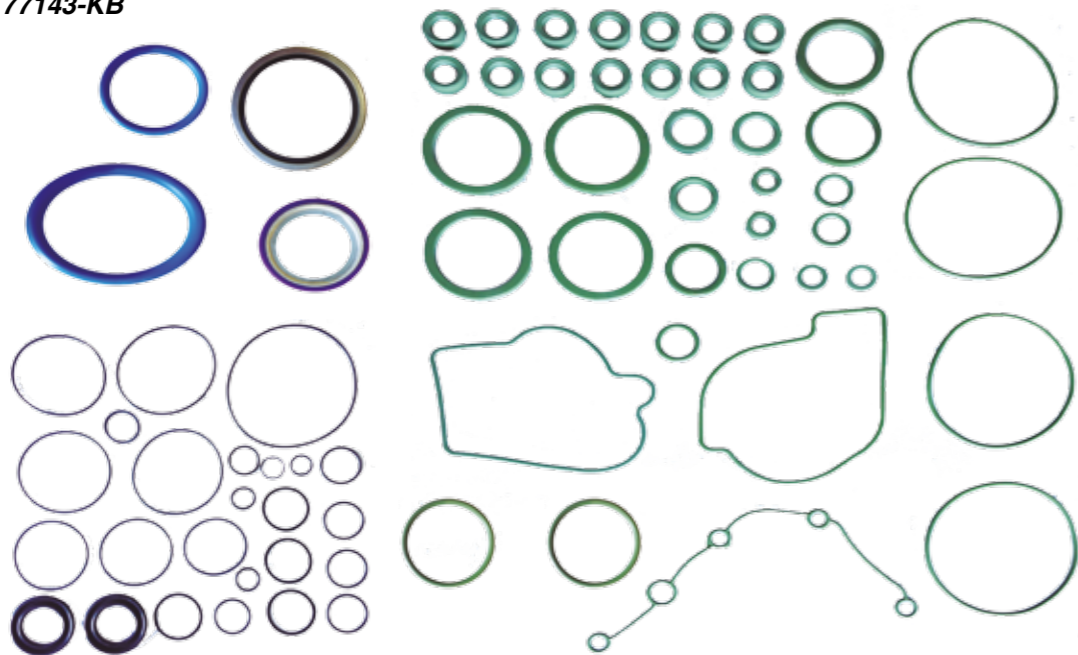

**KIT JUNTAS
77144-KT**

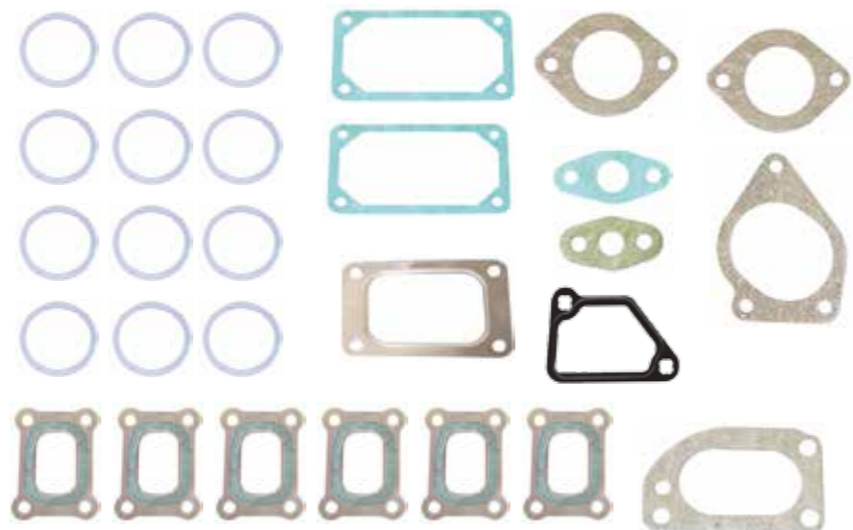

**KIT ARRUELAS
KA 77805**

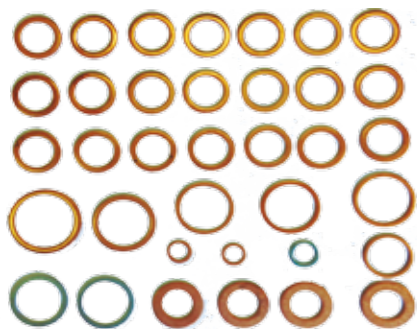

CABEÇOTE COM ANEIS INJETADOS



77776-BI
N° ORIG. 3.099.100

TAMPA DE VÁLVULA

77128-BO
N° ORIG. 8.170.116



JUNTA DO CARTER

77127-BO
N° ORIG. 20.532.272



TAMPA LATERAL DO BLOCO

77136-BO
N° ORIG. 1.677.656

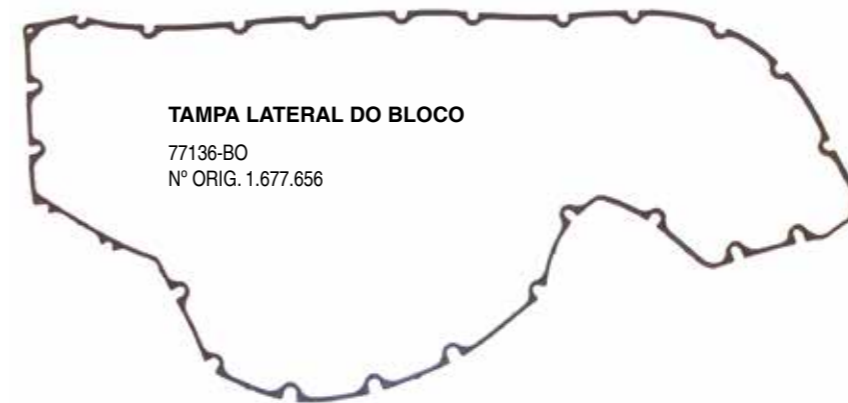

RETENOR TRASEIRO

7441V



RETENOR HASTE VÁLVULAS

8425V



SUPOORTE DO FILTRO



77139-BI
N° ORIG. 1.547.776

INFERIOR DISTRIBUIÇÃO

77137-BO
N° ORIG. 8.170.452



SUPERIOR DISTRIBUIÇÃO

77140-BO
N° ORIG. 8.148.490



FRISO DA DISTRIBUIÇÃO

77141-BO
N° ORIG. 8.148.519



SUPERIOR DISTRIBUIÇÃO

77138-BO
N° ORIG. 8.170.473



ITENS AVULSOS
VOLVO

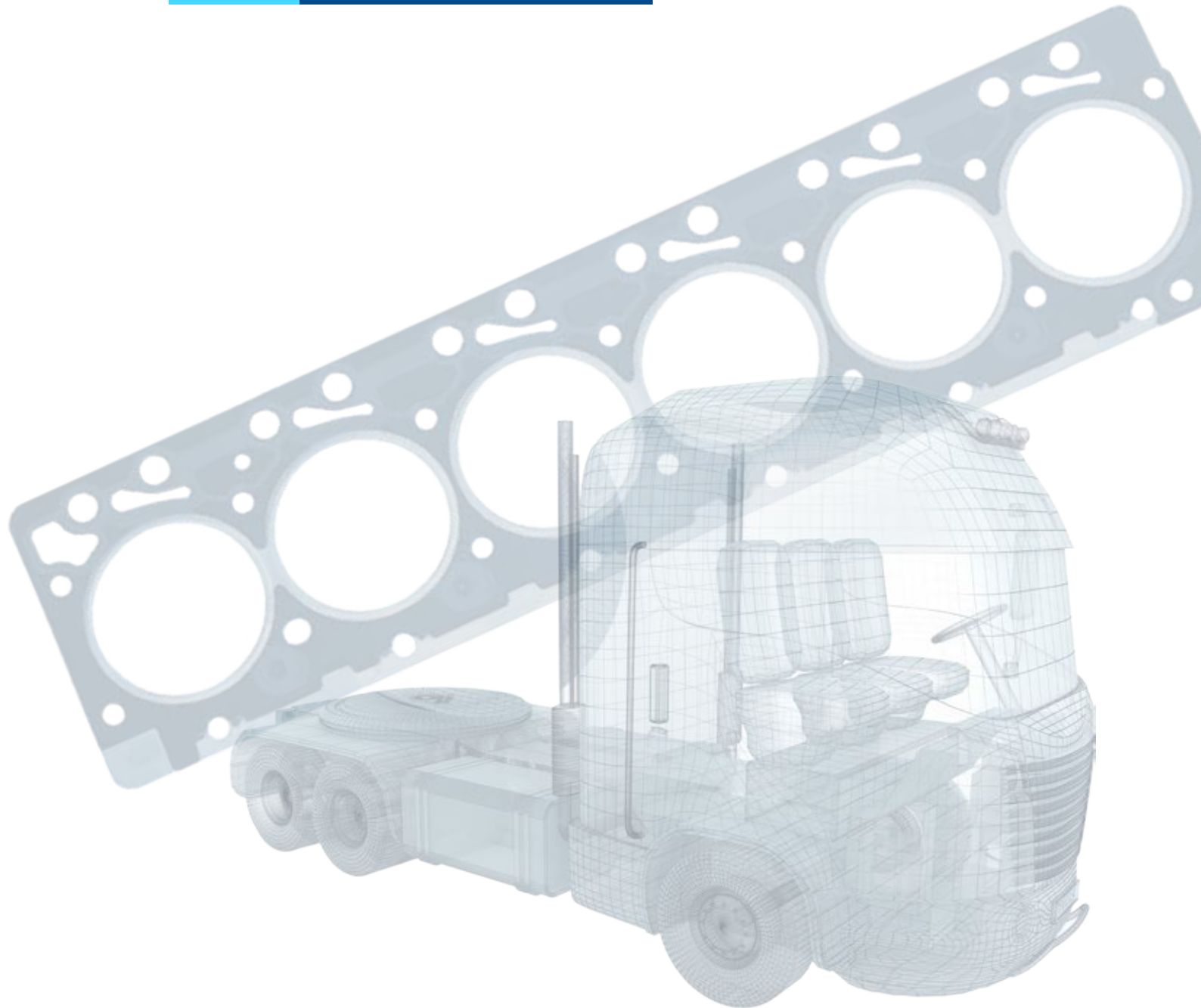

**VOLVO
AVULSOS**

N° CORTECO	APLICAÇÃO
80320ECO e 17060ECO	VOLVO NL-10 / TD-102F / 102FS

CABEÇOTE C/ INSERTOS



82308ECO-OR
N° ORIG. 270.789.0



JUNTA DO CARTER
49116ECO-AN
N° ORIG. 424.127

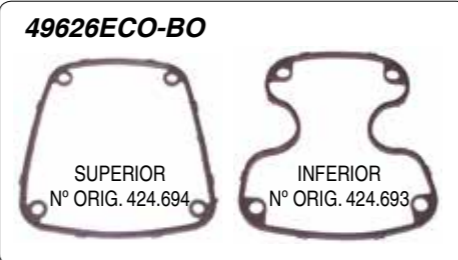

49626ECO-BO



SUPERIOR
N° ORIG. 424.694



INFERIOR
N° ORIG. 424.693

N° CORTECO	APLICAÇÃO
80322ECO e 80321ECO	VOLVO NL-12 / TD122FS C/ RETENTORES

CABEÇOTE C/ INSERTOS



82318ECO-OR
N° ORIG. 275.548.0



JUNTA DO CARTER
49316ECO-AN
N° ORIG. 478.505



TAMPA DE VÁLVULA
49526ECO-BO
N° ORIG. 424.692

N° CORTECO

49012ECO

APLICAÇÃO

VOLVO FH-12

CABEÇOTE COM ANÉIS INJETADOS



99912ECO-BI
N° ORIG. 3.099.100

TAMPA DE VÁLVULA

55990ECO-BO
N° ORIG. 8.170.116

JUNTA DO CARTER

49016ECO-BO
N° ORIG. 20.532.272

LISTA CRUZADA
KITS DE JUNTAS

CORTECO	Sabó	Mahle	Elring	Spaal	Metal Leve
00876ECO		J2138/601	600.876	60460ORRB	
02138ECO		J2138/401		60440ORRB	
13860ECO		JM13860/6	541.933	71612ORML	JRM9206/6
17060ECO			917.060	49007ORBI	
21740ECO		J4841/5450	321.740	48410ORSC	JRM1475/4
33180ECO	48906EFPSD4	J4835/1005650	333.180	48810ORSC	
47904ECO				47904ORBI	
47905ECO				47904ORRV	
47906ECO				47906ORSC	
47924ECO				47924ORRV	
47926ECO				47926ORRV	
48306ECO	48306EFPSD1	J481/1005450	292.130	48308ORSC	JRM1049/4
48404ECO	80394			48404ORBI	JRM9272
48405ECO				48404ORRV	
48606ECO	48606EFPSD	J4841/1005650	324.370	48608ORSC	
48770ECO		JM48770/4		47924ORBI	JRM9296/4
48780ECO		JM48780/6		47926ORBI	JRM9297/6
48806ECO	48806EFPSD1	J481/1005650	333.120	48808ORSC	JRM1049/6
48906ECO	48906EFPSD1	J4810/1005650	333.140	48809ORSC	
48908ECO	48908EFPSD		325.350	48908ORTD	JRM0900/6
48909ECO				48909ORTD	JRM0900/5
49012ECO				49012ORBI	
59501ECO				59501ORRV	
59505ECO				59505ORRV	
59509ECO				59509ORRV	
59806ECO				59806ORBI	
60440ECO				60440ORSC	JRM2304/4
60460ECO			600872	60460ORSC	JRM2304/6
60540ECO				60540ORML	JRM9722/4
60560ECO				60560ORML	JRM9722/6
60660ECO				60660ORSC	JRM9168/6
60760ECO				60760ORSC	JRM9721/6
61406ECO				61406ORSC	
67790ECO		J4899000010110	167.790	48403ORRV	JRS2395/1
70205ECO				70205ORSC	JRM9160/6
70206ECO				70206ORSC	JRM9026/6
70305ECO				70305ORSC	JRM2142/4
70306ECO				70306ORSC	JRM0988/4

CORTECO	Sabó	Mahle	Elring	Spaal	Metal Leve
70906ECO	70906EFPSD	J576/5650		70906CBSC01	JRM0933/6
71004ECO				71004ORSC	JRM2301/4
71103ECO				71103ORTD	JRM2387/6
71104ECO				71104ORTD	JRM2104/4
71105ECO				71105ORTD	
71106ECO				71106ORTD	JRM2180/6
71107ECO				71107ORSC	
71108ECO				71106ORSC	
71109ECO				71107TDRV	
71111ECO				71104TDRV	
71112ECO				71107ORTD	JRM1981/4
71119ECO				71119ORTD	JRM1981/6
71412ECO				71412ORML	JRM9206/4
71413ECO				71412ORRVML	
73320ECO				73320ORML	
73420ECO				73420ORML	
73620ECO				73620ORML	
79906ECO	79906	JS48760/6	492.830	47906ORRV	
79952ECO	79952	J2138/610	600.840	60460ORRV	
79954ECO	79954	J2138/410	600.820	60440ORRV	
80112ECO	80112	J7654/650		59708ORBI	JRM1253/6
80185ECO	80185			70307ORSCVI	JRM1097/4
80270ECO	80270	J4851/650	324.350	48610ORSC	JRM1475/6
80281ECO	80281	J4894/650		48407ORBI	JRM2095/6
80282ECO	80282	J4894/550	499.340	48405ORBI	
80295ECO	80295	J4899000000650	136.290	48403ORBI	JRM2395/6
80320ECO	80320			49006ORBI	
80321ECO	80321			49010ORBI	
80322ECO	80322			49009ORBI	
80325ECO	80325			70106OR	
80326ECO	80326	J4893/10110	324.410	48406ORBI	JRS1894/1
80364ECO	80364	J4841/1005450	499.330	48408ORSC	JRM1807/4
80901ECO	80901			59506ORSC	JRM9113/6
80903ECO	80901			59508ORSC	JRM9119/6
80904ECO	80904	JM48980/4 C/RE	058.724	47904ORSC	JRM9088/4
80906ECO	80906	JM48760/6		47906ORBI	
93310ECO			493.310	60760ORRV	
93330ECO			493.330	60760ORRB	
98950ECO			498.950	47611ORML	

LISTA CRUZADA ITENS AVULSOS

CORTECO	Sabó	Mahle	Elring	Spaal	Metal Leve
01393ECO			001.393	59826BO	
01652ECO			001.652	59816AN	
01796ECO			001.796	48456SI	
25830ECO		J&RC-9119/1	125.830	59503BI	JRC9022/1
33250ECO	48301FPSD4	J4851/1005400	333.250	48301SC	
45561ECO			445.561	47226SI	
47004ECO		JC48780/6		47004BI	
48116ECO	48116EF		700.550	48316CL	
48301ECO	48301FPSD4	J4851/5400		48303SC	
48318ECO	48318F		768.839	48432SC	
48332ECO	48332FS2		778.079	48332SC	
48416ECO				48416AN	
48418ECO				48418AN	
48419ECO				48419NT	
48527ECO	48527EF		748.498	48827CB	
48626ECO	48626F		768.820	48632SC	
48627ECO	48627F		351.939	48627BO	
48716ECO				48716AN	
48802ECO	48802FPSD4		333.240	48601OR	JRC1049/6
48816ECO	48816EF		284.734	48816CL	
48826ECO				48816BILT	
48832ECO	48832EF		777.774	48832SC	
48901ECO				48901TD	JRC0900/3
48902ECO				48902TD	
48917ECO				48917AN	
48926ECO				48926SC	
49016ECO				49016BO	
49116ECO				49116AN	
49316ECO				49316AN	
49526ECO				49526BO	
49626ECO				49626BO	
50320ECO			050.320	47228SI	
53512ECO		JC48770/4	353.512	47002BI	
55990ECO			355.990	49026BO	
59616ECO	59616F		767.174	59616AN	
59626ECO	59626EF		280.623	59626CB	
60116ECO				60116BO	
60117ECO				60116AN	
60216ECO				60216AN	
60326ECO				60326BO	
60327ECO				60327BO	
70101ECO				70101ML	
70102ECO				70102SC	
70103ECO				70103SC	
70115ECO				70115CBLT	
70216ECO	70216F		309.940	70317AN	
70316ECO				70316AN	
70326ECO	70326EF		309.290	70326CB	
70716ECO	70716EF		312.860	70918CB	
70826ECO	70826EF		315.890	70926CB	
70901ECO	70901FPSD	J576/5600	315.940	70901SC	JRC0933/6
71002ECO				71002SC	JRC2301/4
71096ECO				71096NT	
71102ECO				71102TD	JRC1945/1

CORTECO	Sabó	Mahle	Elring	Spaal	Metal Leve
71126ECO	71126EF1		291.890	71126CB	
71127ECO	71127FB1			71426BO	
71716ECO				71716NT	
71816ECO				71816NT	
71916ECO				71916NT	
71917ECO				71917NT	
74790ECO			074.790	47229SI	
74800ECO			074.800	47227SI	
75043ECO	75043		593.120	71826BO	
75058ECO	75058			60626SI	
75295ECO	75295		133.670	47627SI	
75325ECO	75325			70127BO	
75642ECO	75642			60126BO	
75643ECO	75643			60127BO	
75645ECO	75645			60226BO	
75646ECO	75646			60227BO	
75647ECO	75647			60216BO	
75651ECO	75651			59520BO	
75655ECO	75655			59540BO	
75962ECO	75962		600.862	71076BO	
80294ECO	82294	J&RC9272/1		48404BI	
82175ECO	82175	J4835/1005600	333.240	48603OR	
82240ECO	82240	J572/5400	922.501	70301SC	JRC1097/4
82270ECO	82270	J5785/5400	916.463	70101SC	
82283ECO	82283	J2126/5600	601.883	60601SC	JRC9168/6
82284ECO	82284	J2128/5400	590.030	60404SC	JRC2304/4
82285ECO	82285	J2138/5600	590.010	60406SC	JRC2304/6
82295ECO	82295	J4899000005100	462.451	48402BI	
82297ECO	82297		762.811	47611ML	
82308ECO	82308	J714/15100	333.380	49101OR	
82318ECO	82318	J715/15100	333.360	49301OR	JRC1860/1
82352ECO	82352			60504ML	
82354ECO	82354			60506ML	
82412ECO	82412	JC13860/2	585.240	71103ML	JRC9206/2
90040ECO			590.040	60425SI	
93180ECO			493.180	60701SC	
93472ECO		J76061/5100	893.472	59801BI	
95904ECO	95904		211.550	47316NT	
95906ECO	95906		757.310	47317NT	
96027ECO	96027		491.770	60516AN	
96028ECO	96028		491.760	60416AN	
96029ECO	96029		491.780	60616AN	
96120ECO	96120		499.370	48425SC	
96224ECO	96224		175.024	59516AN	
96295ECO	96295			48417AN	
96297ECO	96297		467.722	48457NT	
99297ECO	99297		175.142	47617ML	
99912ECO	99912			49012BI	
99914ECO	99914	JC48980/4	082.724	47001BI	
99916ECO	99916	JC48760/6	082.734	47003BI	
99961ECO	99961	J7654/5300	331.091	59701BI	JRC1253/3
99971ECO	99971	J4893/15100	896.510	48401BI	JRC1894/1
99972ECO	99972			71101TD	JRC2180/1

Obs: O código comercial dos itens avulsos não acompanha a descrição do material. Ex: a peça 82264ECO-SC, o código comercial da mesma é 82264ECO.



Divisão de Reposição



A Freudenberg - Corteco disponibiliza para o mercado de reposição a linha completa de **KITS DE REPARO DE BOMBAS E DIREÇÃO HIDRÁULICA**. São componentes originais desenvolvidos em conformidade com as rigorosas exigências internacionais de qualidade das montadoras e das normas ambientais.





FREUDENBERG-NOK
TECNOLOGIA EM VEDAÇÃO

CORTECO[®]
Divisão de Reposição

Freudenberg-Corteco South America
Av. Piraporinha, 411 - Diadema - SP - Brasil - CEP 09950-902
Tel.: 55 11 4072-8000 - Fax: 55 11 4075-2335
Site: www.corteco.com.br / 0800 194 111
E-mail: cortecobr@fnst.com